

Audi Clamping Adapters

For Audi A-2

Users Manual





CHIEF'S LIMITED ONE-YEAR WARRANTY & LIABILITY

Chief Automotive Technologies, Inc. warrants for one year from date of installation and/or purchase any of its products which do not perform satisfactorily due to defect caused by faulty material or workmanship. Chief's obligation under this warranty is limited to the repair or replacement of products which are defective and which have not been misused, carelessly handled, or defaced by repair or repairs made or attempted by others.

CHIEF AUTOMOTIVE TECHNOLOGIES, INC. DOES NOT ASSUME RESPONSIBILITY FOR ANY DEATH, INJURY OR PROPERTY DAMAGE RESULTING FROM THE OPERATOR'S NEGLIGENCE OR MISUSE OF THIS PRODUCT OR ITS ATTACHMENTS. CHIEF MAKES NO WRITTEN, EXPRESS OR IMPLIED WARRANTY WHATSOEVER OF MERCHANTABILITY OR FITNESS FOR A PARTICULAR PURPOSE OR OTHERWISE REGARDING THE EQUIPMENT OR ANY PART OF THE PRODUCT OTHER THAN THE LIMITED ONE-YEAR WARRANTY STATED ABOVE.

The components of this clamping adapter system are used to anchor the Audi A-2 vehicle which has jack tubes and lift tabs in its rocker panels. The system provides a positive means of securing these vehicles to the EZ Liner mainframe.

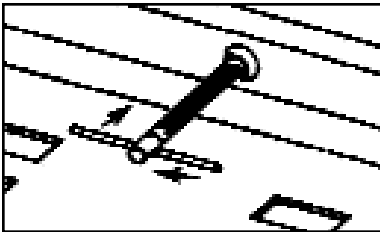

Figure 1

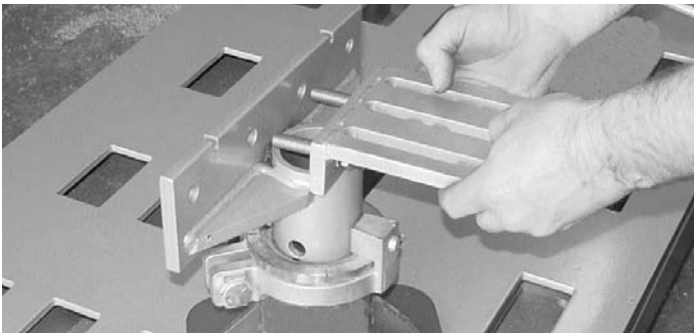

Figure 2

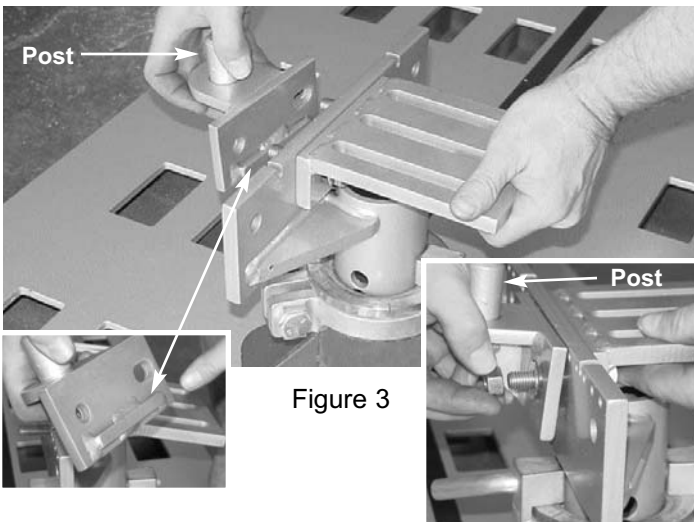

Figure 3

IMPORTANT:

- Information on the use of anchoring stands (including their attachment to the EZ Liner mainframe) appears in the Universal Anchoring Systems Owners Manual. (Part No. 618740.)
- Read all of these instructions prior to using the Audi A-2 Anchoring Accessory.
- Clean jack tubes using one of the anchoring pins. (See Figure 1.)
 - a. Insert a steel punch (or bar) through the 1/2 inch hole at end of pin and use it as a handle.
 - b. Rotate the pin right and left as it is moved in and out of the jack tube hole.

NOTE: Holes must be clean to allow for easy installation and removal of the anchoring assembly.

IMPORTANT: DO NOT use force to drive the pin into the jack tube. Using force to drive the pin into the hole may make it difficult (or impossible) to remove the pin.

- 1) Lift side of vehicle using suitable lifting device and place anchoring stands near front and rear corners of vehicle's center section.
- 2) Position large angle support against back of anchoring stand and insert anchoring bolts through holes in support and through middle holes in anchoring stand. (See Figure 2.)
- 3) Position support plate against front of anchoring stand making sure anchoring bolts project through its mounting holes. (See Figure 3.) Secure the assembly using appropriate nuts and washers. (See Figure 3 Inset at right.)

NOTE: The front support plates are thicker at the bottom than the top. (See Figure 3 Inset at left.) This design positions the support post at a slight outward angle allowing it to mate with the lift tab hole at front of center section.
- 4) Position anchoring stand under front corner of rocker panel and project anchoring tube upward to engage support post with lift tab hole on bottom of rocker panel. Insert the anchoring stand's height adjusting pin to maintain this position.

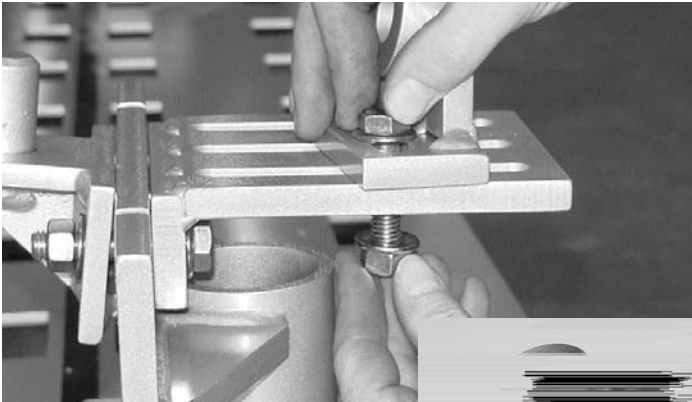

Figure 4

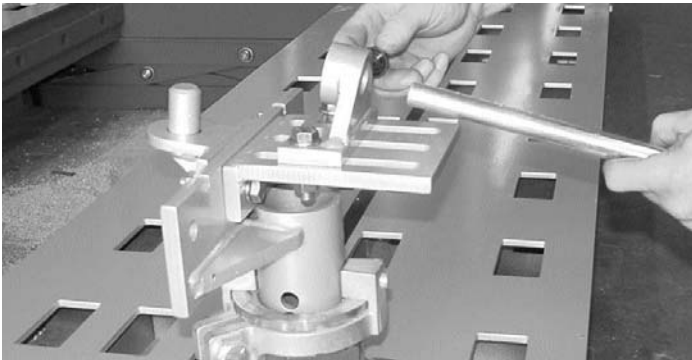

Figure 5

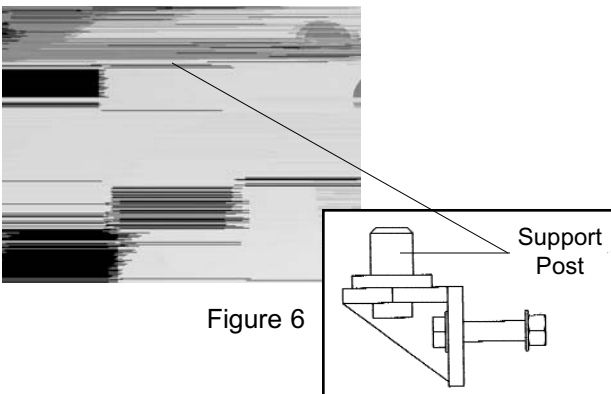

Figure 6

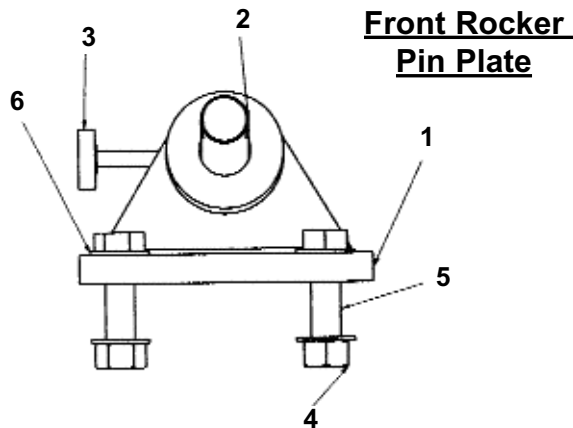

Figure 7

- 5) Attach front rocker pin plate to the large angle support using appropriate size bolts, nuts and washers. Finger tighten only at this time. (See Figure 4.) Figure 4 Inset shows a side view of the front rocker pin plate. Note its symmetrical design.
- 6) Slide front rocker pin plate toward rocker panel aligning the hole in the pin plate with the jack tube in the rocker panel. Position rocker pin plate close to but not touching the rocker. Finger tighten only at this time.
- 7) Insert anchoring pin through hole in rocker pin plate (see Figure 5) projecting it as far as possible into the jack tube. Secure the pin with the thumb screw on the side of the rocker pin plate.
- 8) On same side of vehicle, move to rear of center section and install rear anchoring assembly.

NOTE: The installation procedures at the rear of the center section are identical to the front with two exceptions.

- 1) The support plate mounts flush to the front of the anchoring stand. (See Figure 6 and its Inset.) This design positions the support post at a 90 degree angle allowing it to mate with the lift tab hole at the rear anchoring location.
- 2) The rocker pin plates used at the rear of the center section have a non-symmetrical design. Figure 7 shows the design used at the right rear corner of the center section.
- 9) After installing the front and rear stands on one side of the vehicle, repeat the anchoring procedures on the opposite side of the center section.
- 10) After installing all four stands, adjust each stand to the correct height and tighten all bolts, nuts and washers. Then secure the anchoring stands to the mainframe using tie down plates and bolts.



PARTS ORDERING INFORMATION

To order replacement parts for the Audi A-2 Clamping Adapter System, contact Chief Automotive Technologies, Inc. 800-445-9262. (If outside the United States, contact your nearest Chief Automotive Technologies, Inc. representative.)

When contacting Chief Automotive Technologies, Inc. by telephone or mail, provide the following information: your name, name of your business, business telephone number, and business address. Additional information needed when ordering: description of part(s) and part numbers.

NOTE: Chief reserves the right to alter product specifications and/or package components without notice.

Ref.	Part No.	Description
1	514210	Front Rocker Pin Plate Assembly
2	618302	Anchoring Pin
3	309424	Threaded Screw
4	620736	Nut, 1/2"
5	010628	Bolt, 1/2 x 2
6	019095	Washer, .50 I.D., 16 Gauge

Rear Rocker Pin Plate

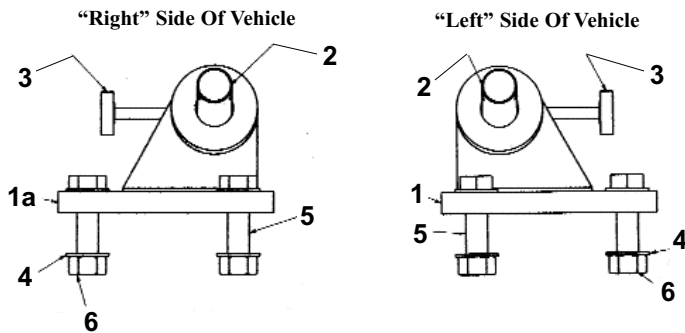

Ref.	Part No.	Description
1	514212	Rear Rocker Pin Plate Ass'y, Left
1a	514211	Rear Rocker Pin Plate Ass'y, Right
2	618302	Anchoring Pin
3	309424	Threaded Screw
4	019095	Washer, 50 I.D., 16 Ga.
5	010628	Bolt, 1/2 x 2
6	620736	Nut, 1/2

Front / Rear Support Plate

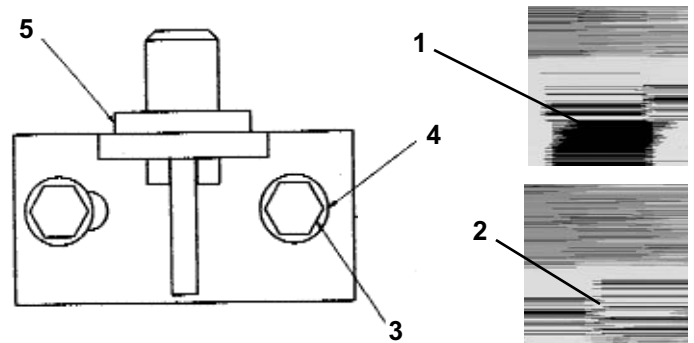

Ref.	Part No.	Description
1	514216	Front Support Plate
2	514217	Rear Support Plate
3	010630	Bolt, 1/2 x 2 1/2
4	019095	Washer, .50 I.D., 16 Ga.
*	620736	Nut, 1/2
5	514218	Spacer, 2 O.D. x 1.142 ID. x 5 /16
*	(not shown in illustration directly above)	

Large Angle Support

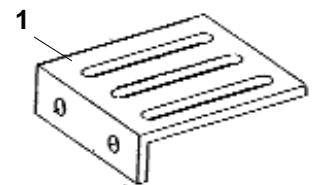

Ref.	Part No.	Description
1	519632	Large Angle Support, main



P.O. Box 1368
Grand Island, Nebraska 68802-1368
Phone 308-384-9747
Fax 308-384-8966

www.chiefautomotive.com

**Chief reserves the right to alter product specifications and/or
package components without notice.**