

# Excellerator

## Parts Manual



### **CHIEF'S LIMITED ONE-YEAR WARRANTY & LIABILITY**

Chief Automotive Systems, Inc. warrants for one year from date of installation and/or purchase any of its products which do not perform satisfactorily due to defect caused by faulty material or workmanship. Chief's obligation under this warranty is limited to the repair or replacement of products which are defective and which have been misused, carelessly handled, or defaced by repair or repairs made or attempted by others.

CHIEF AUTOMOTIVE SYSTEMS, INC. DOES NOT ASSUME RESPONSIBILITY FOR ANY DEATH, INJURY OR PROPERTY DAMAGE RESULTING FROM THE OPERATOR'S NEGLIGENCE OR MISUSE OF THIS PRODUCT OR ITS ATTACHMENTS. CHIEF MAKES NO WRITTEN, EXPRESS OR IMPLIED WARRANTY WHATSOEVER OF MERCHANTABILITY OR FITNESS FOR A PARTICULAR PURPOSE OR OTHERWISE REGARDING THE EQUIPMENT OR ANY PART OF THE PRODUCT OTHER THAN THE LIMITED ONE-YEAR WARRANTY STATED ABOVE.

Returned merchandise requires a "RETURNED GOODS AUTHORIZATION NUMBER" on the package. Authorization numbers can be obtained by calling or writing the Customer Service Department, Chief Automotive Systems, Inc. No returned merchandise will be accepted without an authorization number. All returned merchandise must be shipped freight prepaid (and may be subject to a 15 percent handling and restocking charge) to:

Chief Automotive Systems, Inc.  
Attn: Returned Goods Department  
1924 E. Fourth St.  
P.O. Box 1368  
Grand Island, Ne. 68802-1368  
308-384-9747

Your Authorized  
or Chief Automotive Systems, Inc.  
Representative

## Parts Information

To order replacement parts for the Chief Excelerator System, contact an authorized representative of Chief Automotive Systems, Inc., 1-308-384-9747 or 1-800-445-9262 (USA only).

When contacting Chief Automotive Systems, Inc. by telephone or mail, provide the following information: name, name of business, business telephone number and business address. Additional information needed when ordering: description of parts and part numbers.

**NOTE:** Chief reserves the right to alter parts specifications and/or package components without notice.

**CAUTION:** Always use Chief Automotive Systems, Inc. authorized replacement parts with Excelerator Systems. When replacing any part, make certain the part meets the original equipment requirements.

In addition to general parts information, this parts manual contains Chief's Warranty and Liability Statement, Hydraulic / Pneumatic Diagrams and Machine Specifications.

### Electrical Components

All electrical cords and components must be replaced with Chief Automotive Systems, Inc. authorized replacement parts.

### Hydraulic Hoses

The 1/4" I.D., two wire hydraulic hoses furnished with this product meet the requirements of SAE 100R2 and have a working pressure of 5,000 psi. They should not be used with any other system having a higher than 5,000 psi output. All hydraulic components must be replaced with Chief Automotive Systems, Inc. authorized replacement parts.

### Pneumatic Hoses

The pneumatic components with this product meet the specified requirements and have a working pressure at or above 150 psi. They should not be used with any other system having a higher psi output. All pneumatic components must be replaced with Chief Automotive Systems, Inc. authorized parts.

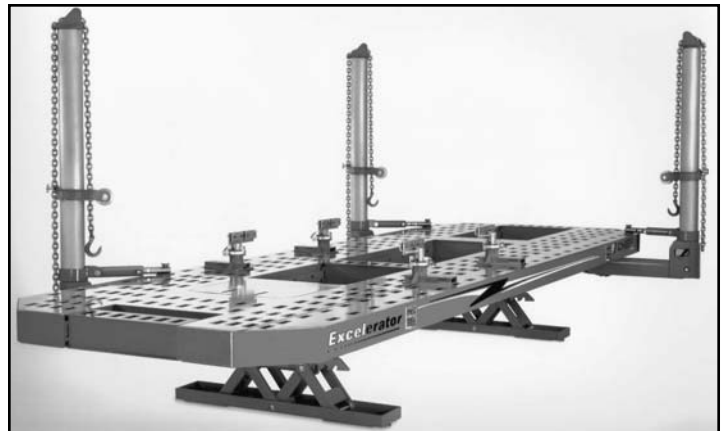

### Bolts and Fasteners

All bolts and fasteners must be replaced with Chief Automotive Systems, Inc. authorized replacement parts and must not be less than Grade 5 (Class 8.8). Any bolt used in a pulling clamp that is frequently tightened must be a Grade 8 (Class 10.9). All bolt lengths and diameters must be equal to those installed at the factory.

### Chain

The 1/2 inch tower chain furnished with this product is a special alloy frame straightening chain designed exclusively for Chief Automotive Systems, Inc. to meet the rigid requirements of the collision repair industry. The 1/2" chain is proof tested to 28,000 lbs. and has a normal working load limit of 13,000 lbs. If replacement is required, purchase only the original Chief product from an authorized Chief Automotive Systems, Inc. representative.

The 3/8" auxiliary chain furnished with this product is a special alloy frame straightening chain designed exclusively for Chief Automotive Systems, Inc. to meet the rigid requirements of the collision repair industry. The 3/8" chain is proof tested to 20,000 lbs. and has a normal working load limit of 7,300 lbs. If replacement is required, purchase only the original Chief product from an authorized Chief Automotive Systems, Inc. representative.

**CAUTION:** DO NOT use the 3/8" auxiliary chain on Excelerator towers.

### Labels

Replacement SAFETY and WARNING labels are available in several languages and may be ordered by contacting an authorized Chief Automotive Systems, Inc. representative.

## Mainframe — Overview

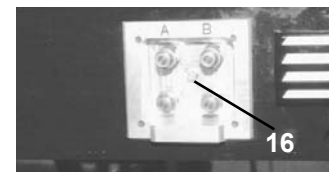
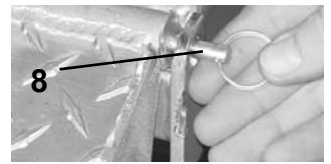
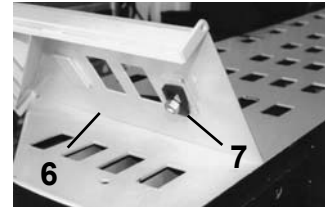
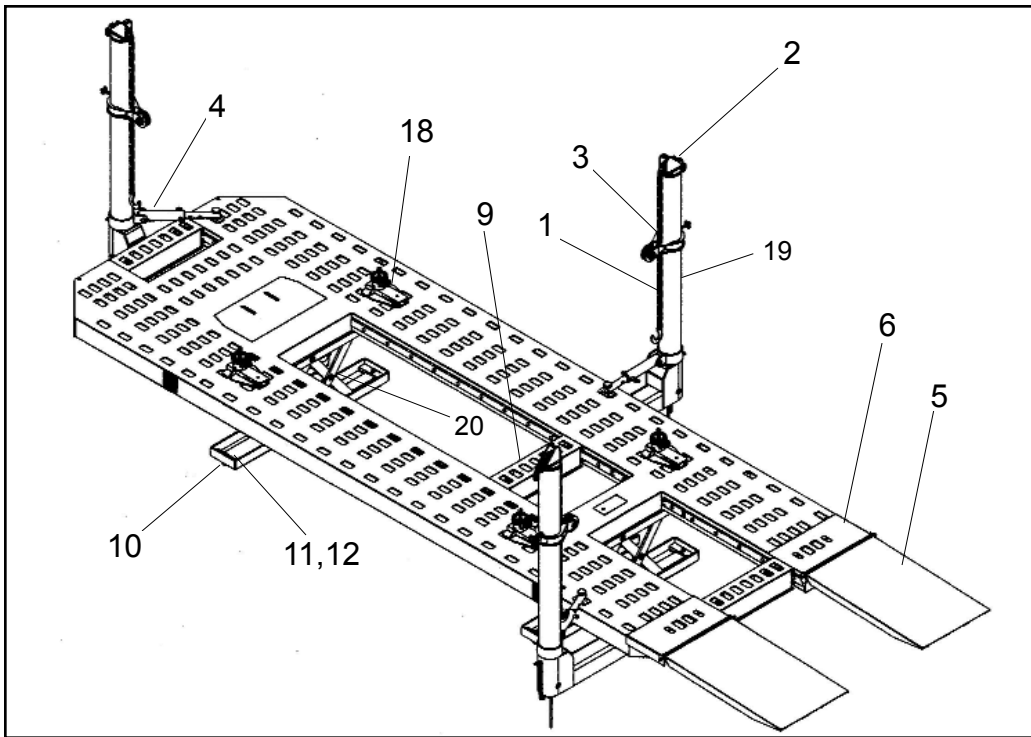

Ref.	Part No.	Description
1	602870	Tower Chain/Hook
2	601169	Tower Head
3	607161	Collar Assembly
4	305548*	Force Arm Assembly
5	305215	Loading Ramps
6	305203	Ramp Pivot Support (RH)
	305202	Ramp Pivot Support (LH)
7	305214	Pivot Support Lock
8	539350	Pin, Ball Dent, 5/32 Dia. x 2" Ring
9	305024*	Crossmember Assembly
10	305051	Leveling Pad
11	305062	Leveling Adjustment Screw
12	692334	Leveling Nut
13	305746	Pressure (Force) Gauge
14	305811	Remote Control, Includes Cord
15	305489	Bar, Rub Rail, Removable (Short)
16	305784	Manifold Plug
17	648880	Wheel Stop
18	702076	Universal Anchoring Stand, Set of 4
19	305536*	Tower Mast/Arm Weldment
20	305178*	Scissor Lift Assembly
21	305038	Screw 10-32 x 1/2 Self-Locking
22	305422	Stainless Trim Ring, Manifold
23	305421	Coupler Guard, Manifold
24	305722	Connector, Male Flat Face
25	305037	Screw 10-32 x 1 Self-Locking
26	305035	Screw, 7/16 x 14 .750 Socket Hd. Cap
27	305293	Weldment, Carriage Stop LH
	305294	Weldment, Carriage Stop RH
28	634012	Bolt, 5/8-11 x 1 1/2 gr. 8 Hex
	*	See also exploded views

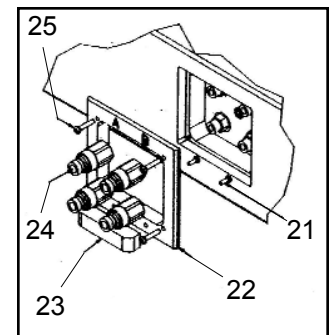
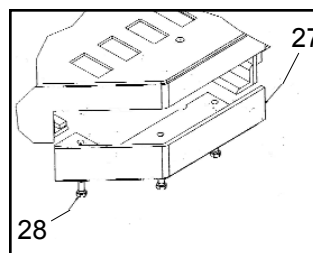
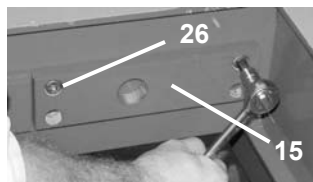
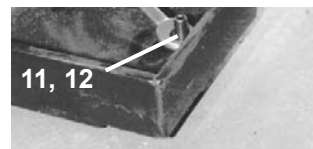
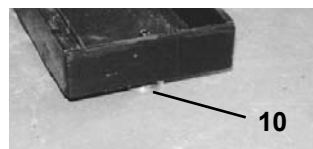

## Crossmember Assembly

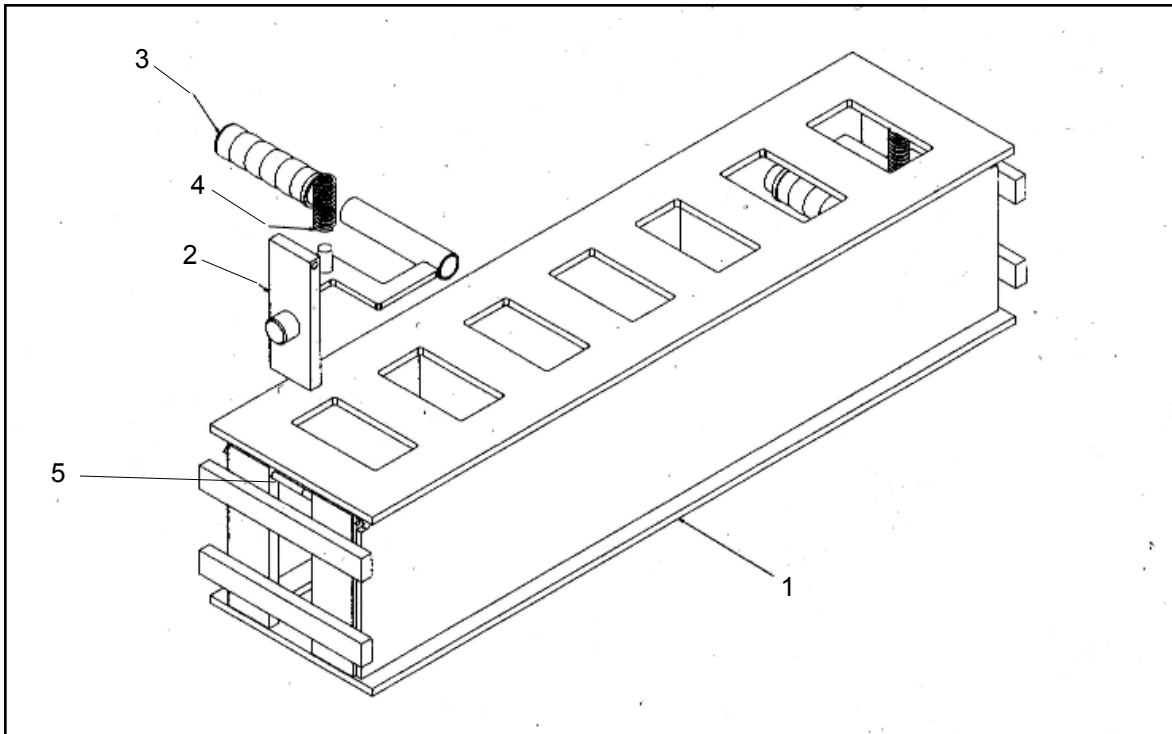

Ref.	Part No.	Description
	<b>305024</b>	<b>Crossmember Assembly</b>
1	305484	Weldment, Crossmember
2	305485	Weldment, Crossmember Release
3	657782	Handle, Lock Pin Auxiliary
4	305066	Spring, 3/4 bore x 2.5 length x k32
5	305039	Screw, 1/4-20 x 4 1/2 Socket Head Cap

## Force Arm Assembly

Ref.	Part No.	Description
	<b>305548</b>	<b>Force Arm Assembly</b>
1	305549	Weldment, Force Arm Tower Collar
2	305557	Weldment, Force Arm Taper Block
3	305552	Tube, Force Arm Outer Telescope
4	305608	Machined Inner Telescope
5	305553	Pin, Grooved 1.00 Dia x 4.81 Long
6	707479	Washer, 1" Thrust Plated
7	770105	HD Retaining Ring
8	305560	Pin, Force Arm Vertical Position
9	305542	Knob, Force Arm
10	305044	Pin, Self-locking Shoulder Style - 3"
11	305045	Pin, Force Arm Taper Block

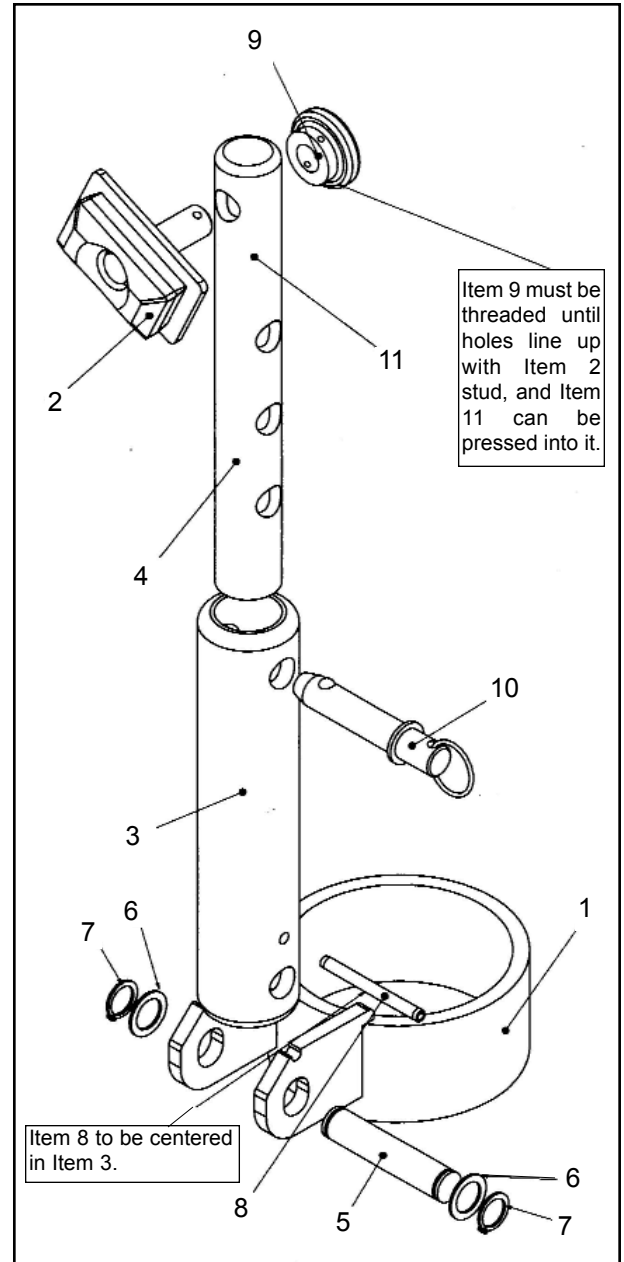

## Manifold Assembly

Ref.	Part No.	Description
	<b>305711</b>	<b>Manifold Assembly</b>
1	305710	Manifold Block
2	305712	Valve, Tandem 3 Position, 4 Way
3	305713	Valve, Double Poppet 2 Way
4	305714	Valve, Normally Open Poppet 2 Way
5	305715	Valve, Normally Closed Poppet 2 Way
6	305718	Coil, 120 VAC, 14 Watt DIN
7	305717	Coil, 120 VAC Series 10-20 Watt DIN
8	305714c	Retainer, Plastic-Included with 305718 Valve
9	305713c	Retainer, Plastic-Included with 305718 Valve
10	305715n	Retainer, Nut-Included with 305715 Valve
11	305712n	Retainer, Nut-Included with 305712 Valve
12	601046	Fitting, Hyd #6MB-#6MJ
13	305721	Fitting, Hyd - 6MB Hollow Hex Plug
14	305729	Flow Control, Pressure Compensated Front
15	305029	#8 Flat Washer

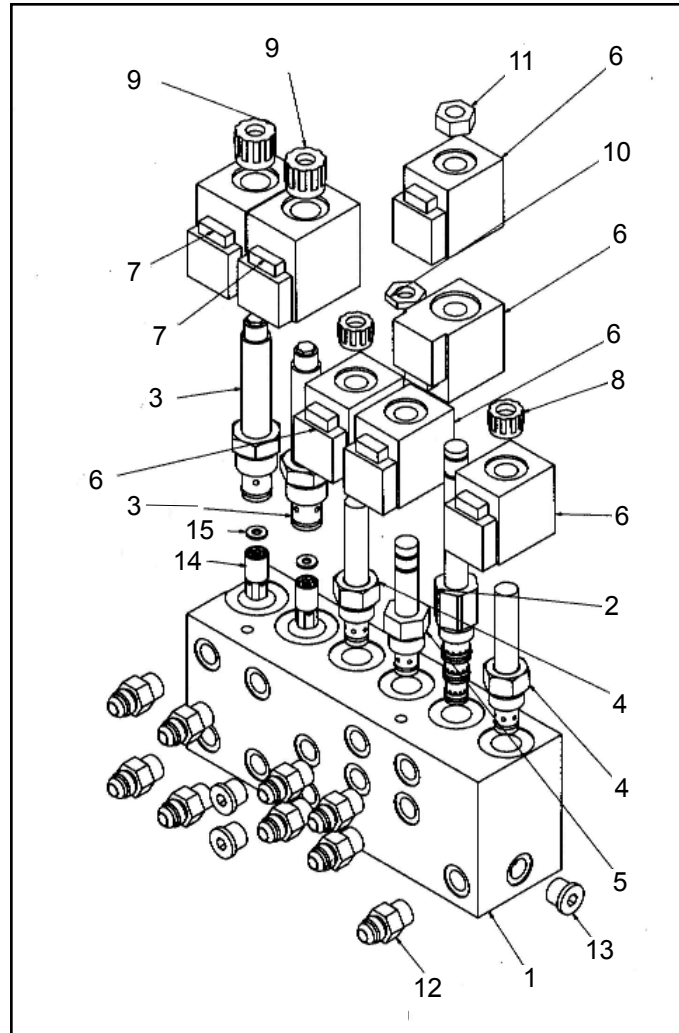

**Tower**  
**(Mast)**  
**Assembly**

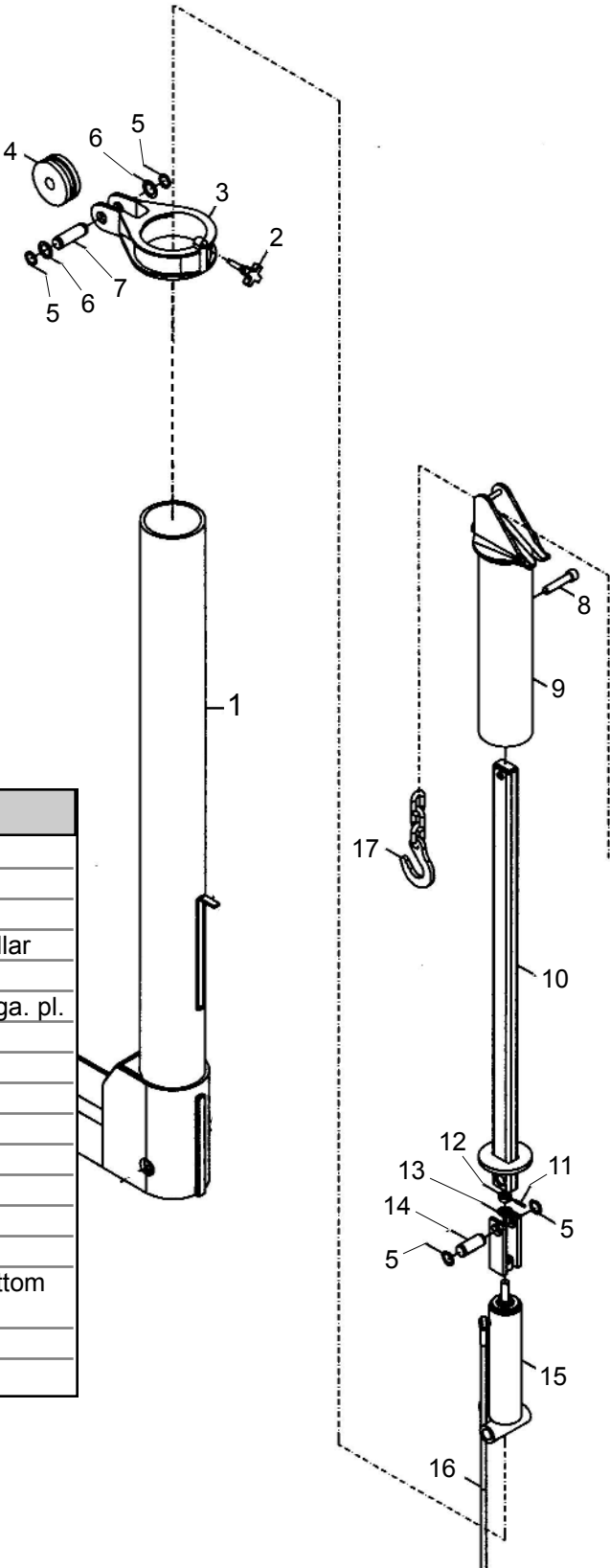

Ref.	Part No.	Description
1	305536	Tower Mast/Arm Weldment
2	602829	Locking Knob, Tower Collar
3	607161	Machined Collar
4	601201	Roller, 5 x 1/2 Chain - S21/Posi Trak Collar
5	693468	Snap Ring, HD for 1 1/4 Shaft
6	707487	Washer, Flat - 1 1/4 ID x 1 7/8 OD x 14 ga. pl.
7	680747	Pin, Grooved for Cast Collar
8	601070	Screw, 3/4-10 x 3.5 Socket Head Cap
9	601169	Tower Head Weldment
10	305538	Tower Linkage
11	601050	Pin, 3/16 x 1 3/8 Spring
12	601055	Nut, 3/4-16 Hex Slotted
13	601738	Washer, 3/4 Flat
14	305189	Pin, Scissor Lift Short
15	305730	Ram, Tower-3" Bore x 10 1/8 Stroke, Bottom Load
16	305727	Tower Hydraulic Line Assembly
17	602870	Chain, 10-Ton

## Tower (Arm) Assembly

Ref.	Part No.	Description
1	305536	Tower Mast/Arm Weldment
2	305574	Bar, Carriage Release
3	305067	Grip, Carriage Release Bar
4	707487	Washer, Flat-1 1/4 ID x 1 7/8 OD x 14 ga. pl.
5	693468	Snap Ring, HD for 1 1/4 Shaft
6	11059	Screw, 1/4-20 x 1 3/4 SHC
7	305567	Washer, Cable Release Retainer
8	305730	Ram, Tower-3" bore x 10 1/8 Stroke, Bottom Load
9	305419	Pin, Tower Cylinder Retainer
10	12452	Bolt, 1/4-20 x 1/2 Hex Head
11	18069	Nut, 1/4-20 Hex
12	305528	Force Arm Inner Telescope Assembly
13	305057	Spring, Die, 5/8 Bore x 1 1/2 Long x 656k
14	629853	Washer, 1/4 Split Lock
15	305530	Housing Cap, Tower Lock Arm
16	305527	Spring Pusher, Tower Arm Lock
17	305036	Bushing, 3 1/2 Bore x 2 3/8 Length DU
18	305380	Washer, Tower Arm to Carriage Pin Thrust 1/8 Thick
19	305383	Cap, Tower Arm to Carriage Retainer
20	629837	Washer, 3/8 Split Lock
21	305034	Nut, 3/8-24 Hex
22	697029	Bolt, 3/4-10 Countersunk Socket Head Cap Screw
23	305065	Cam Follower, 7/8 Roller x 3/8-24 Thread Sealed Stud Type
24	305568	Cable Jacket, Carriage Release

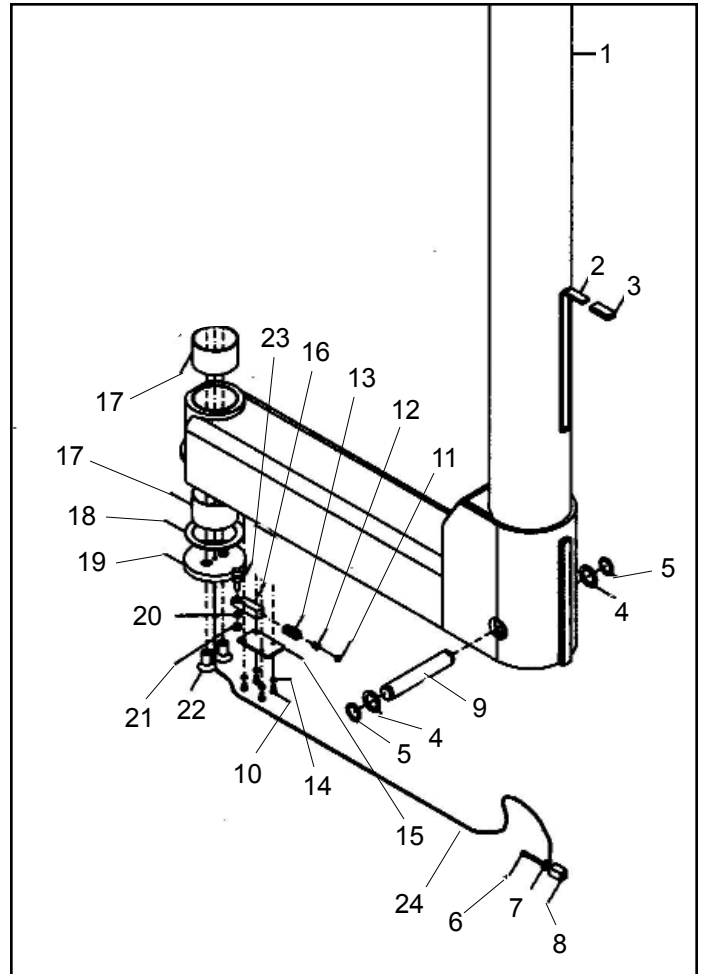

## Tower Carriage Assembly

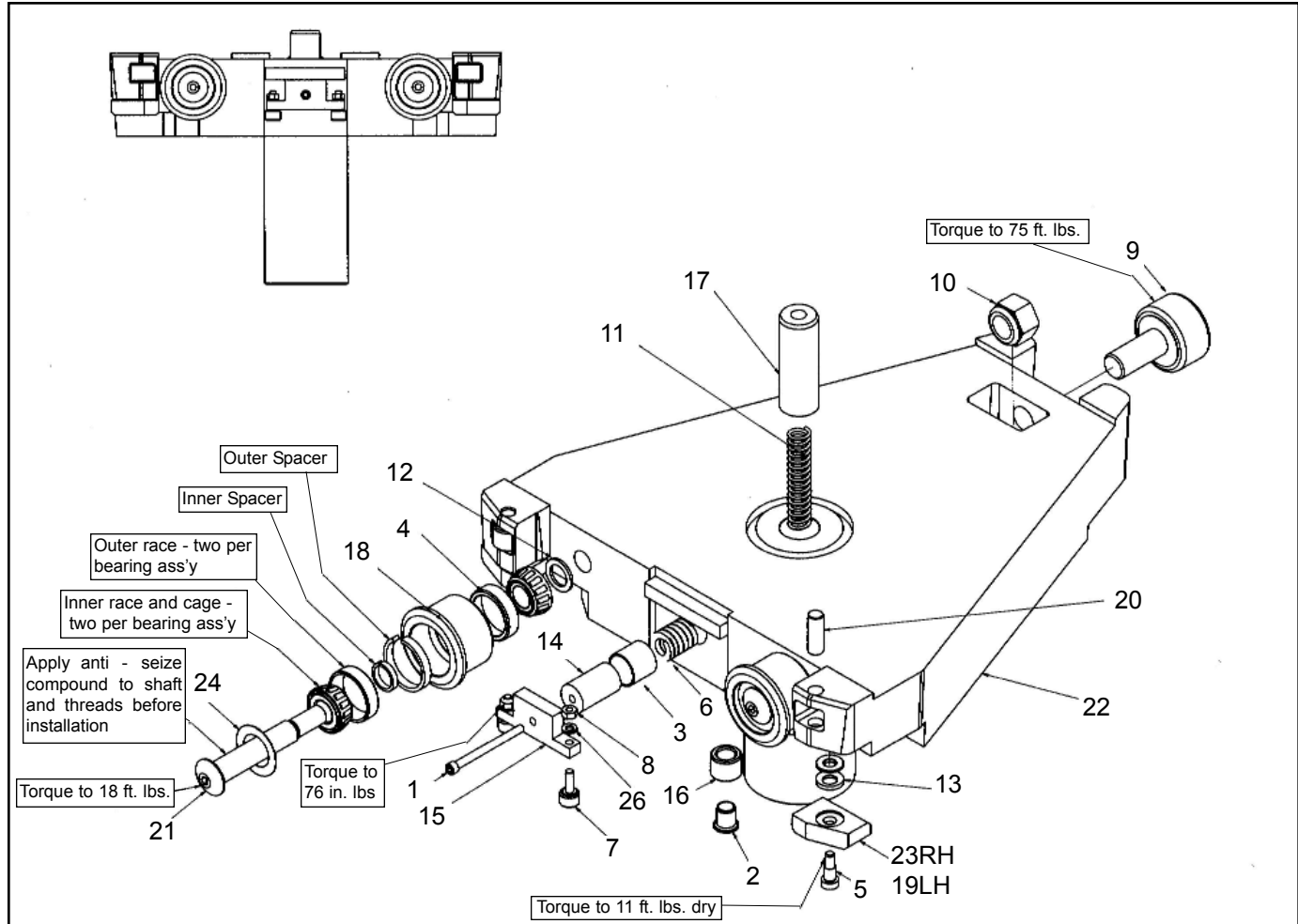

Ref.	Part No.	Description
	<b>305493</b>	<b>Tower Carriage Assembly</b>
1	011064	Screw, 1/4-20 x 3.0 Socket Hd Cap
2	305026	Bushing, 1/2 bore x 3/4 Long DU Flange
3	305027	Busing, 1" bore x 1" Long DU
4	305032	Bearing Set, Double Taper
5	305033	Screw, 5/16-18 Thread 3/8 x 1/2 Shoulder
6	305053	Spring, 1" Bore x 1 1/2 Length Extra Heavy Die
7	305055	Cam Follower, 5/8 Roller x 1/4 - 28 Thread Sealed Stud
8	305056	Nut, 1/4-28 Hex
9	305058	Cam Follower, 2 1/4 OD 7/8-14 Thread Sealed Stud Type
10	305060	Nut, 7/8-14 Hex Nylock
11	305061	Spring, 1" Bore x 3.5 Long Hvy Duty

Ref.	Part No.	Description
12	305063	Washer, 3/4 ID x 1 1/4 OD x 3/32 Thick Shim
13	305064	Spherical Washer Set
14	305338	Pin, Carriage Tensioner
15	305341	Bar, Carriage Tensioner
16	305347	Roller, Carriage Vertical
17	305353	Pin, Carriage to Deck
18	305448	Wheel, Carriage Outside
19	305492	Rest Pad, Carriage LH
20	305494	Vertical Pin
21	305497	Axle, Carriage
22	305498	Weldment, Carriage
23	305499	Rest Pad, Carriage RH
24	305504	Washer, Bearing Dust Cover
25	692334	Nut, 5/8-11 Hex Jam
26	629853	Washer, 1/4 Split Lock

## Scissor Lift

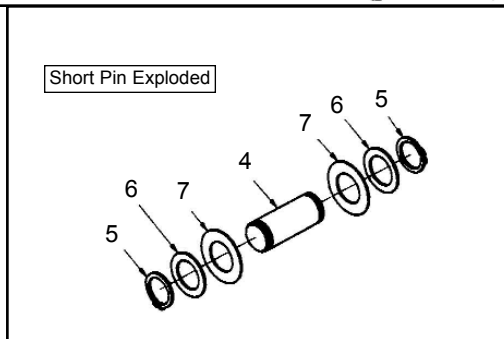
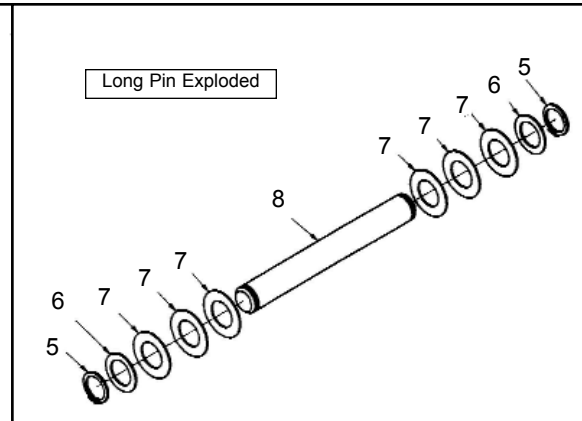
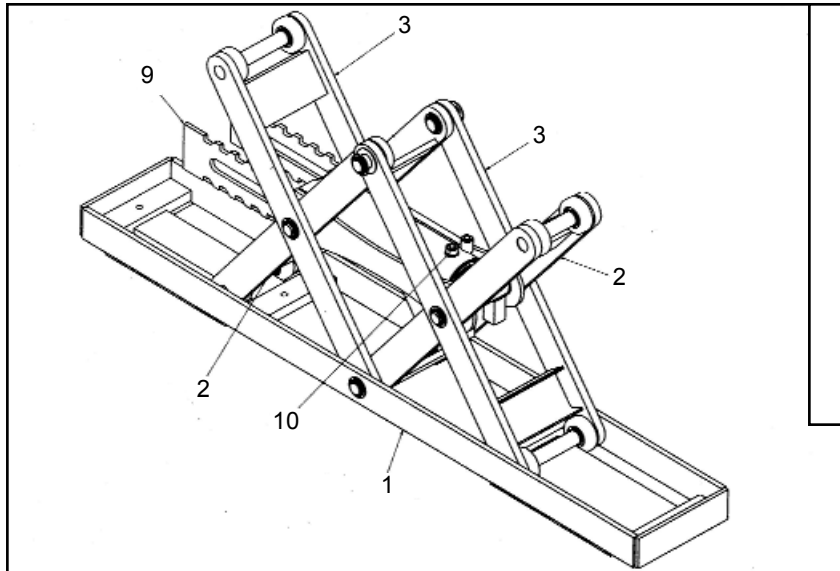

Ref.	Part No.	Description
	<b>305178</b>	<b>Assembly, Scissor Lift</b>
1	305168	Weldment, Scissor Channel
2	305170	Assembly, Inner Scissor Leg
3	305176	Assembly, Outer Scissor Leg
4	305189	Pin, Scissor Lift Short
5	693468	Snap Ring, HD for 1 1/4 Shaft
6	707487	Washer, Flat-1 1/4 ID x 1 7/8 OD x 14 ga. pl.
7	305030	Washer, Thrust-1 1/4 ID x 2 1/2 OD x 1/16 Self Lubricating
8	305161	Pin, Scissor Lift Long
9	305184	Lock Arm, Excelerator Herringbone
10	305445	Assembly, Lift Cylinder

## Hydraulic System Components

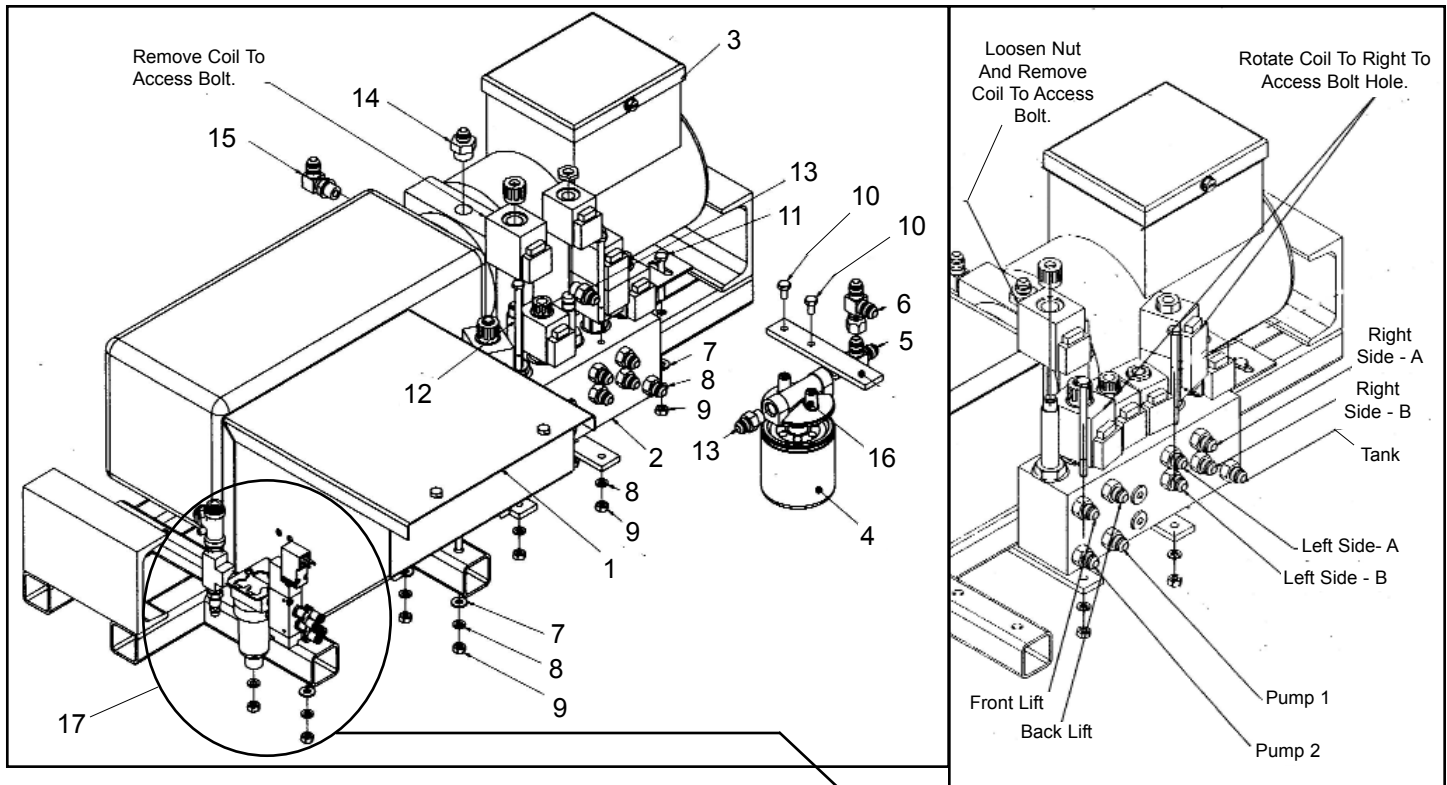

Ref.	Part No.	Description
1	305823	Control Box Assembly
2	305711	Assembly, Control Manifold
3	305700	Power Unit, 220VAC Double w/2.5 gallon reservoir
4	305735	Filter, Return Line
5	305748	Fitting, Hyd. - 6MBX - 6MJ-6MJ Run T
6	305749	Fitting, Hyd. - 6FJX - 6MJ-6MJ Run T
7	707410	Washer, 1/4 Flat
8	629853	Washer, 1/4 Split Lock
9	629247	Nut, 1/4-20 NC gr. 2 Hex pl.
10	012452	Screw, 1/4-20 x 1/2
11	629781	Bolt, 1/4-20 NC x 2" gr. 2 Hex pl.
12	706302	Bolt, 1/4-20 NC x 4" gr. 5 Hex pl.
13	601046	Straight Adapter, 6400-6-6
14	305752	Straight Adapter, 8MB-6MJ
15	305720	Fitting, Hyd. - 6MBX-6MJ
16	305736	Filter Head
17	305777	Valve Assembly
18	305780	Solenoid Valve, 2 pos-5way
19	305781	Filter
20	305785	Fitting, 1/8 NPT Short Nipple
21	305786	Fitting, Male Y, 1/8 NPT to 5/32 PTF
22	305787	Breather, 1/8 NPT
23	305788	Fitting, Adapter, 1/4 NPT to 1/8 NPT
24	305789	Fitting, 1/4 NPT Union T
25	305790	Fitting, Male Run T, 1/4 NPT to 3/8 PTL
26	305791	Coupler, Pneumatic

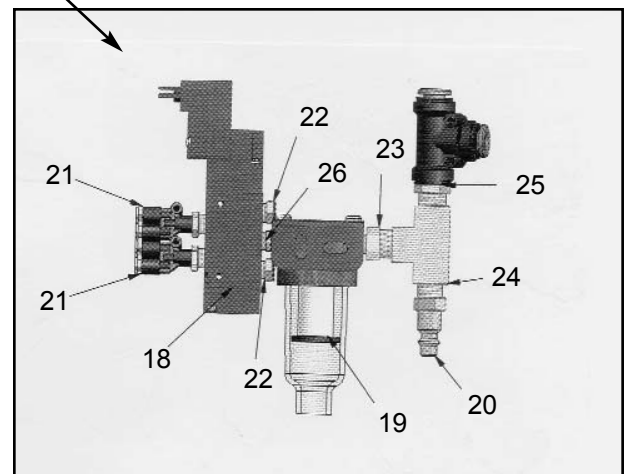

## Decal Packages

Decal Package	Part No.	Req'd	Description
<b>Chief Excelsator</b>  <b>305095</b>	305080	2	Decal, Excelsator
	305081	2	Decal, "Z" Art
	305082	2	Decal, Chief EZ Liner
	305083	6	Decal, Tower Gusset Indian Head
	305084	44'	Tape, Black Striping 1"
	305085	6	Label, WARNING — Excelsator Force Arm
	305086	6	Label, CAUTION — Excelsator Crossmember
	305087	6	Label, CAUTION — Excelsator Tower Arm
	305088	4	Label, CAUTION — Excelsator
	305089	1	Label, CAUTION — Excelsator Machine Operation
	305090	1	Label, IMPORTANT — Excelsator Oil Reservoir
	305091	4	Label, CAUTION Excelsator Safety Lock Arms
	305092	6	CAUTION, Excelsator — Objects Clear Of Tower
	305093	6	Label, CAUTION — Excelsator Wheel Stops
	305094	1	WARNING, Excelsator DO NOT Enter Enclosure
	692140	2	Decal, 308 - 384 - 9747
	692143	2	Label, CAUTION : Lifting Of Persons Is Prohibited
	693337	3	Label, WARNING DO NOT Position Yourself
	693338	1	Label, WARNING — Fire
	693339	2	Label, CAUTION, Egress / Ingress
	693340	1	Label, Nuts, Bolts & Clamps
	683673	4'	Tape, Red, 1" Wide

Decal Package	Part No.	Req'd	Description
<b>Mainframe Excelsator</b>  <b>305099</b>	305080	2	Decal, Excelsator
	305081	2	Decal, "Z" Art
	305082	2	Decal, Chief EZ Liner
	305086	6	Label, CAUTION — Excelsator Crossmember
	305088	4	Label, CAUTION — Excelsator
	305089	1	Label, CAUTION — Excelsator Machine Operation
	305090	1	Label, IMPORTANT — Excelsator Oil Reservoir
	305091	4	Label, CAUTION — Excelsator Safety Lock Arms
	305093	6	Label, CAUTION — Excelsator Wheel Stops
	305094	1	WARNING, Excelsator — DO NOT Enter Enclosure
	692140	2	Decal, 308 - 384 - 9747
	692143	2	Label, CAUTION : Lifting Of Persons Is Prohibited
	693338	1	Label, WARNING — Fire
	693339	2	Label, CAUTION, Egress / Ingress
	093340	1	Label, Nuts, Bolts & Clamps

Decal Package	Part No.	Req'd	Description
<b>Tower Excelsator</b>  <b>305097</b>	693337	1	Label, WARNING — DO NOT Position Yourself
	305092	2	Label, CAUTION — Excelsator Objects Clear Of Tower
	305087	2	Label, WARNING — Fire
	305085	2	Label, WARNING — Excelsator Force Arm
	305083	2	Decal, Tower Gusset Indian Head



## Control Manifold Layout

Part No. 305711

- L1 = To Front Lift
- L2 = To Rear Lift
- P1 = Pressure In From Pump 1
- P2 = Pressure In From Pump 2
- T = To Filter And Then Tank
- A1 = Supplies "A" Side
- A2 = Supplies "B" Side

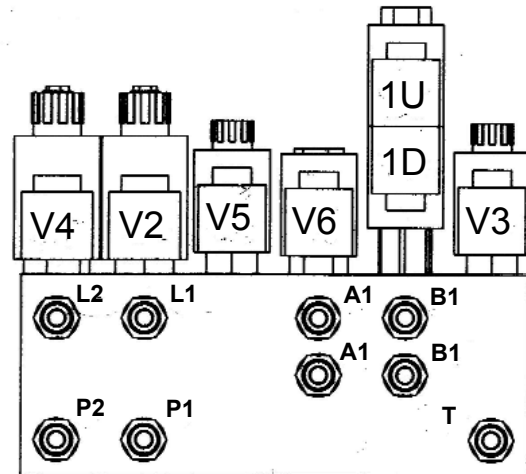

## Machine Specifications

<b>Weight Of Machine</b>	9,860 lbs (with three towers)
<b>Lift Capacity</b>	8,500 lbs.
<b>Power Required</b>	220V/60Hz. single phase, 16 amps (20 amp breaker)
<b>Hydraulic Power</b>	10 tons per tower (89kN) at the hook
<b>Hydraulic Fluid</b>	L SUS 215 Viscosity, 100 Degrees F (38C), 10W
<b>Controls</b>	Programable logic control with 5 button cord deck size controller
<b>Length</b>	22' mainframe only 27' 9" w/ towers extended to front and rear 23' 6 1/2" w/one tower extended 26' 2" w/loading ramps installed
<b>Width</b>	.89" mainframe only 119" with one tower extended to side 148" with two towers extended to both sides
<b>Tower Height</b>	.108 1/2" with mainframe at highest working height 128" with tower extended at end of mainframe and opposite end of mainframe at lowest working height 118" with mainframe at highest working height and tower head extended upward
<b>Clearance</b>	.150" required on all sides
<b>Working Heights</b>	.34" 33" 31" 29" 26" 22" 18"
<b>Tie Down Openings</b>	.299
<b>Radius Of Pull</b>	.360 degrees



**P.O. Box 1368  
Grand Island, Nebraska 68802-1368  
Phone 308-384-9747  
Fax 308-384-8966**

**INTAIRCO S.A.R.L.  
CA de TREMBLAY CHARLES DE GAULLE  
18, rue Henri FARMAN  
93297 TREMBLAY EN FRANCE CEDEX  
TEL 01 41 51 16 80  
FAX 01 48 60 09 88**

**[www.chiefautomotive.com](http://www.chiefautomotive.com)**