

FUZION

USERS MANUAL



CHIEF'S LIMITED ONE-YEAR WARRANTY & LIABILITY

Chief Automotive Technologies warrants for one year from date of installation and/or purchase any of its products which do not perform satisfactorily due to defect caused by faulty material or workmanship. Chief's obligation under this warranty is limited to the repair or replacement of products which are defective and which have not been misused, carelessly handled, or defaced by repair or repairs made or attempted by others.

CHIEF AUTOMOTIVE TECHNOLOGIES DOES NOT ASSUME RESPONSIBILITY FOR ANY DEATH, INJURY OR PROPERTY DAMAGE RESULTING FROM THE OPERATOR'S NEGLIGENCE OR MISUSE OF THIS PRODUCT OR ITS ATTACHMENTS. CHIEF MAKES NO WRITTEN, EXPRESS OR IMPLIED WARRANTY WHATSOEVER OF MERCHANTABILITY OR FITNESS FOR A PARTICULAR PURPOSE OR OTHERWISE REGARDING THE EQUIPMENT OR ANY PART OF THE PRODUCT OTHER THAN THE LIMITED ONE-YEAR WARRANTY STATED ABOVE.

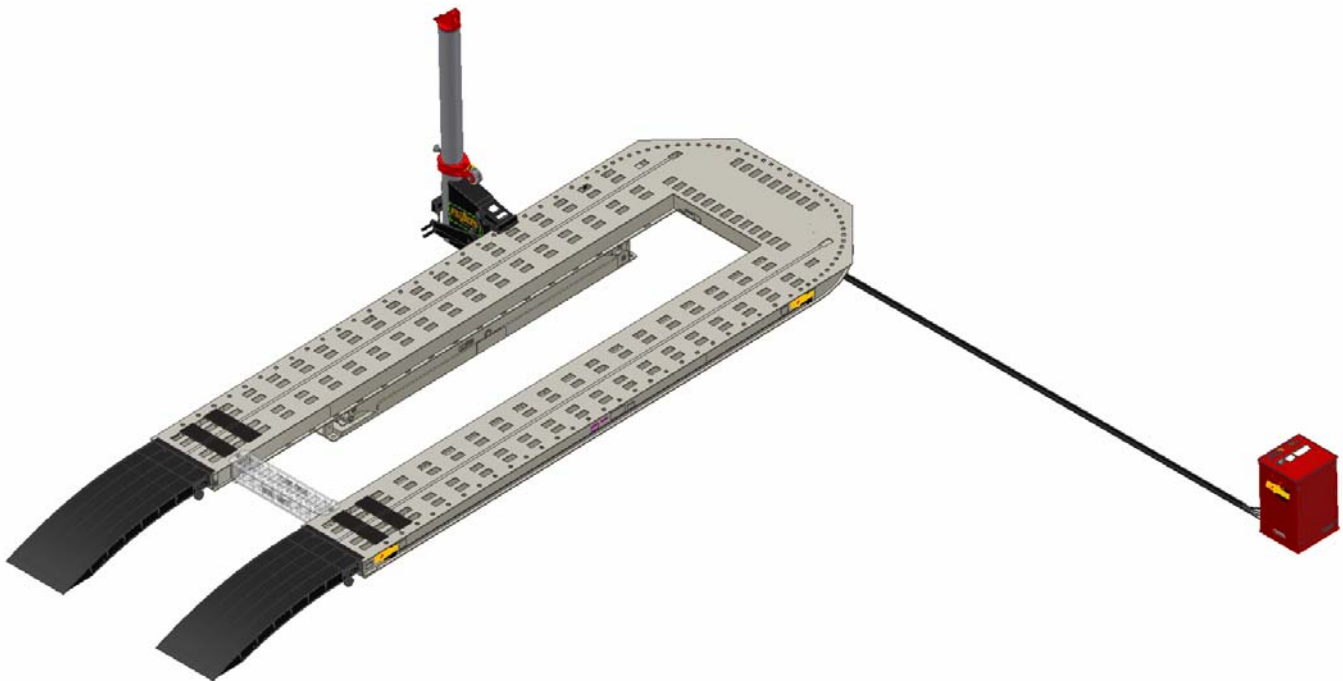

This owner's manual is written to familiarize operators with the safe and efficient operation of the Chief FUZION system. The FUZION machine features unibody and full frame repair capabilities with pulling access around three sides of the vehicle.

One tower is provided with the FUZION and up to three more can be added as optional equipment. Each tower mounts to the bottom plate of the mainframe. A unique tower roller design allows easy movement around the machine and a "Sure-Lock" force clamp secures the tower to the mainframe when making a pull. Each tower is equipped with a hydraulic ram operated by an electric over hydraulic pump. The machine is hydraulically positioned at various working heights and tilts hydraulically for either drive-on or winch-on positioning of vehicles.

NOTE: Illustrations shown in this manual may vary slightly from actual product

This manual is not intended to replace Chief Automotive training. For information concerning training, contact Chief Automotive Technologies.

IMPORTANT:

1. DO NOT attempt to operate the Chief FUZION without first reading this entire manual.
2. Complete safety information is highlighted throughout this manual and is identified by: 
3. This safety alert symbol identifies safety information. Operator injury could result if these CAUTION notes are not followed.
4. Qualified service personnel must check operational capacity of the FUZION system prior to its initial use and at intervals of no more than one year. Contact your authorized Chief Automotive Technologies representative for inspection.
5. Persons operating the FUZION system must be at least 18 years of age, must be trained in the operation of the FUZION system, and must have demonstrated their qualifications to the employer. They must also be specifically assigned to operate the FUZION system by the employer and this assignment must be in writing.

IMPORTANT SAFETY INSTRUCTIONS

When using your garage equipment, basic safety precautions should always be followed, including the following:

1. Read all instructions.
2. Care must be taken as burns can occur from touching hot parts.
3. Do not operate equipment with a damaged cord or if the equipment has been dropped or damaged – until it has been examined by a qualified service person.
4. Do not let a cord hang over the ledge of the table, bench, or counter or come in contact with hot manifolds or moving fan blades.
5. If an extension cord is necessary, a cord with a current rating equal to or more than that of the equipment should be used. Cords rated for less current than the equipment may overheat. Care should be taken to arrange the cord so that it will not be tripped over or pulled.
6. Always unplug equipment from electrical outlet when not in use. Never use the cord to pull the plug from the outlet. Grasp plug and pull to disconnect.
7. Let equipment cool completely before putting away. Loop cord loosely around equipment when storing.
8. To reduce the risk of fire, do not operate equipment in the vicinity of open containers of flammable liquids (gasoline).
9. Keep hair, loose clothing, fingers and all parts of the body away from moving parts.
10. To reduce the risk of electric shock, do not use on wet surfaces or expose to rain.
11. Use only as described in this manual. Use only manufacturer's recommended attachments.
12. **ALWAYS WEAR SAFETY GLASSES.** Everyday eyeglasses only have impact resistant lenses, they are not safety glasses.

General Safety Tips

General



DO NOT operate this machine unless:

1. You are authorized in writing by your employer.
2. All towers are properly secured to machine.
3. Vehicle's wheels are blocked and parking brake is set.
4. Load is 12,000 lbs or less.
5. Field of motion of load carrying device is free of persons and obstructions.



Persons operating the FUZION repair system must be at least 18 years of age, must be trained in the operation of the FUZION system, and must have demonstrated their qualifications to the employer.



DO NOT attempt to operate the FUZION pulling system without first reading this entire manual.



Always wear safety glasses when using the FUZION machine or any of its accessories.



Maintain a free space of 20 inches (50cm) minimum around all moving parts and pinch points on machine.

Rigid, Optional, and Rolling Crossmembers



DO NOT use any crossmember as a step.



DO NOT use any crossmember to make angular pushes or pulls.



During removal and reinstallation of any crossmember, hold crossmember firmly to support its weight. Use a helper if needed. Following installation of rigid and optional crossmembers, install support pins at each end of crossmember to prevent accidental disengagement.



To avoid damage to lift assemblies or mainframe, crossmember must be installed and located properly when raising or lowering equipment.

Collar



To avoid accidental dropping of tower collar, tighten collar locking knob and/or lower collar to bottom of tower.



Collar locking knob must be tightened before removing tower chain from vehicle.

Tower Movement



WARNING!

Fully engage "Sure-Lock" force clamp with pinning hole on mainframe to prevent tower movement during the pull or during a raising or lowering procedure.



When pushing tower, keep one hand on tower lever and the other on the tower pipe above the collar. Also, keep hands away from all pinch points... i.e. roller assemblies on bottom mainframe plate and force clamp pinning location on top mainframe plate.



When engaging "Sure-Lock" force clamp, keep hands away from all pinch points... i.e. roller assemblies on bottom mainframe plate and force clamp pinning location on top mainframe plate.

NOTE: Hoses may need to be disconnected when moving towers around the front and rear of machine.

Pulling



WARNING!

To avoid severe personal injury to yourself and others: DO NOT position yourself close to, or in-line with chains, clamps, or other accessories while pressure is applied to this system.



To Prevent personal injury from flying objects:

- Check all bolts, nuts, and clamps for deformation or elongation prior to each use.
- Deformed or elongated materials must be replaced.
- If materials look deformed, they are deformed. Replace them.



Remove twist in chain before applying pressure to chain.

Raise / Lower Machine



When raising or lowering machine, secure towers to front of mainframe. The "Sure-Lock" force clamps must firmly engage pinning holes at the location and tower levers must be down.



Lifting of persons is prohibited.











Keep feet and objects clear of mainframe when lowering machine.



Raise / Lower Machine (continued)

-  To avoid personal injury or damage to equipment before operating the machine, make sure:
Persons and objects are clear of machine.
Hoses and other objects are free of the lift legs
Oil spills must be cleaned up immediately to prevent slipping. Hoses on the floor can create a tripping hazard.









Loading / Unloading Machine

-  Prior to driving or winching vehicle on or off the machine make sure loading ramps are installed correctly.
-  When driving or winching a vehicle on or off machine, use helper to guide you. If vehicle's brakes are inoperable, use a Chief winch and refer to instructions packaged with that accessory.
-  Immediately after positioning vehicle on mainframe, put vehicle in park (if automatic transmission), apply vehicle's emergency brake, and have helper install wheel chocks at "front" of front tire and at "rear" of rear tire. Install wheel chocks as close to the tires as possible to prevent vehicle movement and keep wheel chocks installed whenever vehicle is not anchored to mainframe.
-  Position vehicle far enough onto mainframe so that wheels do not rest on loading ramps. DO NOT use ramps to lift or hold a load off of the floor. Remove ramps before raising machine.
-  Before lowering machine, put vehicle in park (if automatic transmission), apply vehicle's parking brake, and install wheel chocks. Then check to make sure loading ramps are installed correctly.
-  DO NOT run over air hoses or hydraulic lines when loading or unloading vehicles.
-  DO NOT exceed the machine's 12,000 lbs. (5,443 kg) lifting capacity.
-  When raising or lowering machine with vehicle aboard, DO NOT walk behind rear of machine.
-  Always install wheel chocks when raising or lowering machine with a vehicle aboard.

Chain

-  The ½" tower chain is proof tested to 28,000 lbs. (124kN).
-  To avoid personal injury or damage to property, DO NOT:
 - Heat chain or hook while repairing vehicle. 600 8F (316 8C) of heat on chain will weaken it.
 - Tip load chain hook
 - Pull with twisted chain links

Hydraulics

-  Keep pump away from excessive heat or flames. The surrounding temperature should not exceed 122° F (508 C).
-  Always release hydraulic pressure before disconnecting hydraulic hoses.
-  If pump fails to shut off, disconnect electrical supply and contact an authorized Chief Automotive Technologies service representative.
-  All components must be replaced with Chief Automotive Technologies authorized replacement parts.
-  Improper handling and/or modification of parts is forbidden and may cause a hazardous situation for the user. Such action immediately voids the warranty and releases the manufacturer from all liability.
-  Keep pump cabinet in upright position. DO NOT lay pump on its side.
-  Fill pump reservoir with all cylinders retracted and deck in loading position. (see maintenance section).
-  DO NOT overfill pump reservoir.

Operational Capacity

-  Qualified service personnel must check operational capacity of FUZION system prior to its initial use and at intervals of no more than one year. Contact your authorized Chief Automotive Technologies representative for inspection.

Optional Steps / Ladders

-  Use only approved steps and ladders when working on or around this equipment.

Shop Hopper



To avoid injury, always use an assistant when lifting and positioning anchoring crossbars.



When making heavy pulls, tie the anchoring bases back to the deck using a chain and turnbuckle assist.



Keep loads centered.



Always have assistance when moving shop hopper.



Avoid sloped surfaces whenever possible.



If a sloped surface must be crossed, use extreme caution and always roll straight up and down the slope, NEVER sideways to it.



Always apply wheel brakes when parked.



During docking, entire perimeter of Shop Hopper is a potential pinch point. Take care when raising and lowering the deck to load and unload the Shop Hopper.

Hydraulic System Components

General

The Chief FUZION is powered by an electrically operated hydraulic pump, which is operated by a remote control pendant. Refer to the FUZION parts manual (Chief #638011) for component detail.

Hydraulic pressure is distributed to tower cylinders, auxiliary cylinders, and lift cylinders. The flow of hydraulic fluid to tower and auxiliary cylinders is controlled by individual valves located in each auxiliary line. The flow of hydraulic fluid to the lift cylinders is controlled by an electric switch mounted on the pump cabinet top panel. Hydraulic pressure is monitored by gauges mounted on the towers.

NOTE: Although the FUZION is a low pressure system, it builds hydraulic pressure quickly. Be aware of this quick reaction when making pulls or lifting vehicles.

IMPORTANT: Tower cylinders and auxiliary cylinders can be operated either simultaneously (with equal hydraulic pressure) or individually. The lift cylinders must not be operated while any tower or auxiliary cylinders are operating. Whenever using the hydraulic system, close all valves where hydraulic pressure is not required.

⚠ WARNING: To avoid personal injury or damage to property: When disconnecting hydraulic quick couplers, some fluid spillage may occur. Always clean up any hydraulic fluid spillage from floor or work area.

Initial Setup

The FUZION requires a compressed air supply to activate the safety lock releases. Before using the FUZION, it is necessary to install a customer supplied air coupler. The FUZION cabinet is equipped with a 1/4" Female NPT port on the back. (See figure 1)

The FUZION cabinet must be connected to the hydraulic cylinders at the front of the machine lift linkages. Each bundle of lines goes to one cylinder. First connect the black pneumatic lines to the fittings by the cylinders. (To connect a pneumatic line, firmly push the hose into the fitting until it is fully seated.) Next, connect the hydraulic hoses to each cylinder. Finally, plug the square electrical connectors into the valve on each cylinder and tighten the screws. (See figure 2)

IMPORTANT: When connecting hose bundles, check for any interferences of lines with moving parts.



Figure 1

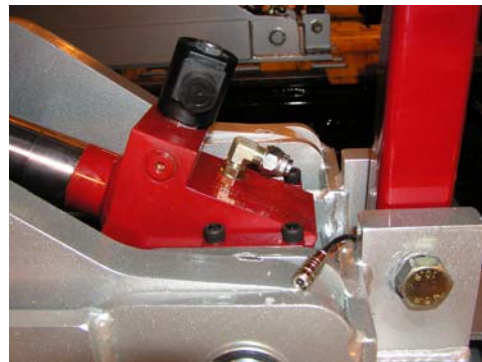

Figure 2

Initial Setup Of Hydraulic System

After all connections are made the excess air in the hydraulic cylinders must be bled. First read the next section on pump usage then lift the Fuzion to its highest position. Press the down button on the pendant until the Fuzion completely settles into the top locking height.



WARNING

Personal injury or property damage may occur if the cylinders are bled when the machine is not in a locked working position.

Next, use an allen wrench to loosen one of the plugs at the top of a cylinder one full turn. (See figure 3) Briefly run the pump in the up direction until clear oil comes out from around the plug. Use a shop rag to capture the oil from the plug. Finally, tighten the plug and repeat the process for the other cylinder. The cylinders must be bled each time the hoses are disconnected.

Rephasing Of Hydraulic System

The hydraulic system of the Fuzion has two independent cylinders and linkage systems. During normal use, it is possible for one side to get slightly higher or lower than the other. For this reason, it is necessary to rephase the hydraulic system every time the machine is raised or lowered.

To insure the Fuzion deck is in a level position, the machine must be fully settled into one of five fixed positions. This includes the four working height positions (locking positions) and the tilted loading position.

When raising the Fuzion, listen carefully to hear the lock mechanisms drop into the locking positions. Be certain that both lock mechanisms have dropped into the same desired locking position before lowering the machine.

Once at the desired height, simply press and hold only the down button on the pendant. This will allow the Fuzion to settle into a working position and be level. Hold the down button for a few seconds after the machine has stopped moving to assure that the system has completely settled. Do this every time the Fuzion is raised for safety and for leveling purposes.



WARNING

To prevent personal injury or property damage: Be certain the machine has fully settled into a working position after raising or lowering the machine.



Figure 3

Pump Usage

To activate hydraulic pump to apply pressure to system to raise machine or towers, depress "UP" button on the hand-held control pendant. (See figure 4). The pump will build hydraulic pressure in the system to activate lift, tower, or auxiliary hydraulic cylinders.

To disengage the hydraulic pump, release the "UP" button on the hand-held control pendant. This action stops the flow of hydraulic oil to the system being operated: however, the system holds existing hydraulic pressure.

To release hydraulic pressure, depress the "DOWN" button on the hand-held control pendant. (See figure 5). This will release the hydraulic pressure in the system and return hydraulic oil to the pump reservoir.

**CAUTION:**

To prevent damage to the pump and hydraulic cylinders, DO NOT operate pump when cylinders are fully extended. (If possible, stop supplying pressure before cylinders reach full extension)

Towers

The FUZION repair system is equipped with one pulling tower that can be positioned anywhere along the sides and front of the machine. The system can accommodate up to three additional towers. All towers feature telescoping heads, adjustable collars, and a unique roller assembly that not only secures the tower to the bottom of the machine, but also allows easy movement around the machine's perimeter track.

Also unique to this system is the "Sure-Lock" force clamp that secures the tower to circular pinning holes along the outer edge of the mainframe. The force clamp secures the tower to the mainframe while removing stress from the roller assembly.

Tower pulls can be set up quickly and are controlled by a hand-held pendant, which controls the flow of hydraulic pressure, and individual tower valves which control the flow of oil to each tower. The vertical angle of the pull is controlled by adjusting the up and down position of the tower collar on the tower pipe. The horizontal angle of the pull is adjusted by tower placement and the rotation of the tower collar on the tower pipe.

**CAUTION:**

The 1/2 " (13 mm) tower chain is proof tested to 28,000 lbs. (124 kN)



Figure 4



Figure 5

To Operate Towers

1. Step on “Sure-Lock” release handle to unlock “Sure-Lock” force clamp from mainframe. (See figure 6).
2. Rotate “Sure-Lock” handle forward to fully open “Sure-Lock”. (See figure 7).
3. Push tower to desired location on machine. (See figure 8).



CAUTION:

When pushing tower, keep one hand on “Sure-Lock” lock handle and the other on the tower pipe above the tower collar. Also, keep hands away from all pinch points... i.e. roller assemblies on bottom of mainframe plate and force clamp pinning locations on top mainframe plate.



Figure 6



Figure 7



Figure 8

To Operate Towers (continued)

- To secure tower to mainframe, rotate “Sure-Lock” lock lever back and down to engage “Sure-Lock” force clamp with mainframe pinning hole. (See figure 9). Fully lock “Sure-Lock” by stepping on lock lever. “Sure-Lock” force clamp is fully engaged when outer tower rollers are raised above outer track. (See figure 10).

⚠ WARNING

Fully engage “Sure-Lock” force clamp with pinning hole on mainframe to prevent tower movement during the pull or during a raising or lowering procedure.

⚠ CAUTION: When engaging “Sure-Lock” force clamp, keep hands away from all pinch points... i.e. roller assemblies on bottom mainframe plate and force clamp pinning location on top mainframe plate.

- To adjust slack tower chain, grip chain on each side of tower. Lift out on tail of chain until it is approximately 45 degrees from tower. Then disengage chain from tower head and pull chain to either increase or decrease amount of slack. (see figure 11)
- Support collar with one hand while loosening collar locking knob with opposite hand. Then position collar approximately three inches (75 mm) above desired pulling height and retighten collar locking knob. (see figure 12)
- Let tower chain hang free momentarily to remove twist. Then without twisting chain, attach hook to vehicle. Pull on tail end of chain to remove slack (see figure 13). Loosen collar locking knob and lower collar.

IMPORTANT: Remove twist from chain before lowering collar. Make sure that chain links between collar roller and hook align.



Figure 9



Figure 10

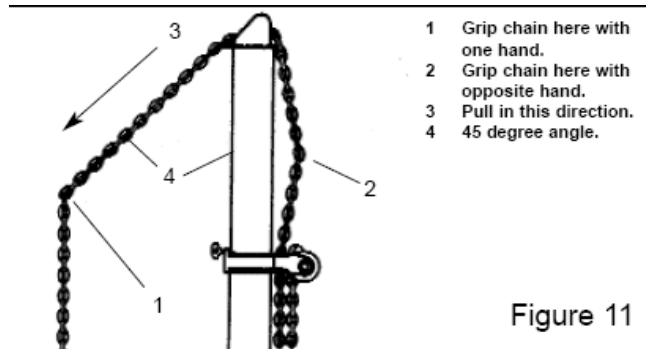

Figure 11

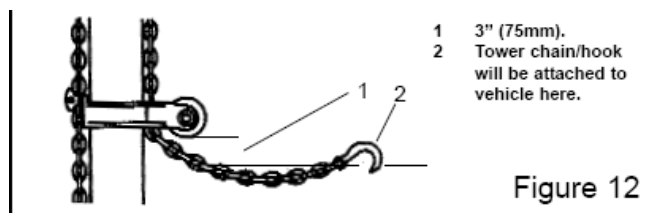

Figure 12

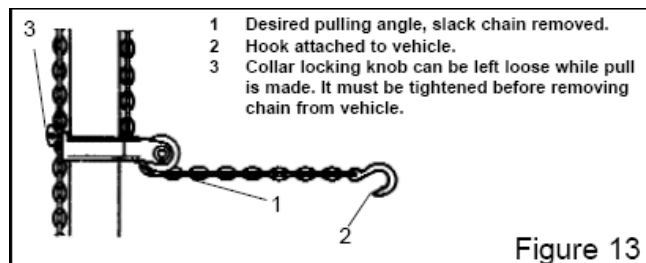

Figure 13

To Operate Towers (continued)

8. Attach pump's hydraulic hose to tower quick coupler. (see figure 14)
9. To operate pump, follow usage procedures on page 8.

CAUTION: To prevent damage to tower assembly, pulls must not exceed a 45 degree angle from tower base. (see figure 15)

CAUTION: To avoid personal injury or damage to equipment, DO NOT:

- Heat chain hook while repairing vehicle. 600 8F (316 8C) of heat on chain will weaken it.
- Tip load chain hook.
- Pull with twisted chain links.

WARNING

To avoid severe personal injury to yourself and others: DO NOT position yourself close to or in-line with the chains, clamps, or other accessories while pressure is applied to this system.

IMPORTANT:

- DO NOT tighten collar locking knob while pressure is applied to the system because it will be impossible to loosen the knob without pressure on the system.
- DO NOT wrap tower chain around track nor attach tower hook to track. Damage to track will impede tower usage.

When tower is no longer needed, disconnect hydraulic hose from tower's quick coupler, remove tower chain and hook from vehicle, and store collar using one of the two methods shown in figures 16 & 17.

CAUTION:

- Collar locking knob must be tightened before removing tower chain and hook from vehicle.
- Collar locking knob must be tight when collar is not in use.
- Store collar at bottom of tower pipe or support collar with tower chain.



Figure 14

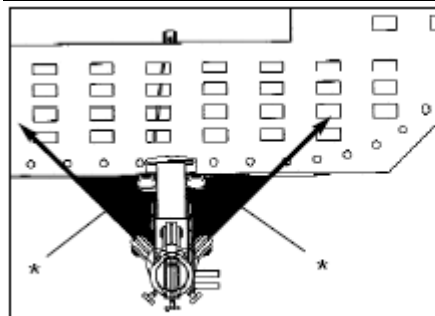

* Pulling Angle Must Not Exceed 45 Degree Range From Tower Base.

Figure 15

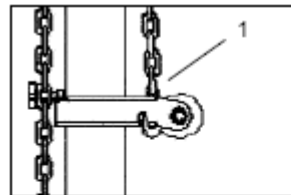

Figure 16

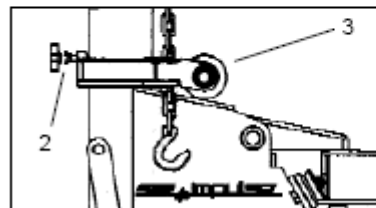

Figure 17

- 1 Collar supported by Tower Chain.
- 2 When collar and chain are stored this way, collar locking knob must be tightened before removing tower chain and hook from vehicle.
- 3 Collar rests on tower base.

Optional Crossmember

General

An optional crossmember is available for the FUZION system. The crossmember (see figure 18) mounts to the inside edges of the bottom deck plate and can be moved forward or rearward as needed. The crossmember does not lock to the machine; however, support pins (see figure 19) prevent it from being accidentally disengaged.

The primary use of the crossmember is to support perpendicular pulls and pushes. In both instances, the optional auxiliary ram or Chief air jack must be positioned perpendicular with the top or bottom of the crossmember.

To install the crossmember, hold it securely while rotating it into position. (see figure 18) Both ends of the crossmember must engage the bottom mainframe plate. Then secure support pins (see figure 19) at each end of the crossmember.

**CAUTION:**

- DO NOT use movable crossmember as a step.
- DO NOT use movable crossmember as a base to make a hydraulic pull or push unless auxiliary ram is positioned perpendicular (90 degrees) with top or bottom of crossmember.
- Reinstall support pins at each end of crossmember to prevent accidental disengagement.
- DO NOT make angular pulls or pushes from the crossmember.

Crossmember locks are included with the crossmember to help prevent unintentional movement of the crossmember. (See figures 20 and 21) Always engage the crossmember locks when not repositioning the crossmember.



Figure 18



Figure 19

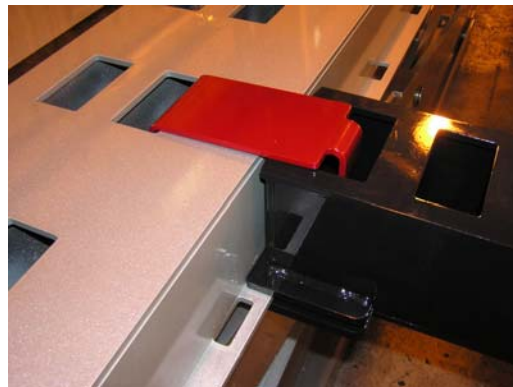

Figure 20



Figure 21

Lowering / Raising Machine

General

When lowering or raising a machine with a vehicle aboard observe the following precautions.



CAUTION:

- When driving or winching vehicle on or off machine, use a helper to guide. (See figure 22) If vehicle's brakes are inoperable, use a Chief winch and refer to instructions packaged with that accessory.
- When vehicle is on mainframe, all wheels must clear loading ramps. (See figure 23) DO NOT attempt to lift machine with vehicle's wheels on the loading ramps. Remove ramps before raising machine.
- Immediately after positioning vehicles on mainframe, put vehicle in park (if automatic transmission), and apply vehicle's emergency brake. Continue to depress brake pedal until helper installs wheel chocks (see figure 24) at "front" and "rear" of machine.
- Prior to lowering machine, put vehicle in park (if automatic transmission), apply vehicle's emergency brake, and install wheel chocks at front of front tires and rear of rear tires. Then install loading ramps at rear of machine.
- Keep vehicle's wheels blocked during raising and lowering procedures and whenever vehicle is not anchored to machine.
- When raising or lowering machine with vehicle aboard, DO NOT walk behind machine.
- DO NOT exceed 12,000 lbs. Lifting capacity of FUZION system.



Figure 22

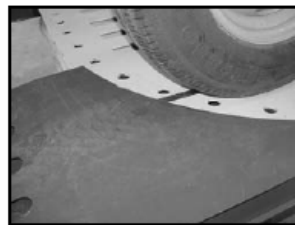

Figure 23



Figure 24

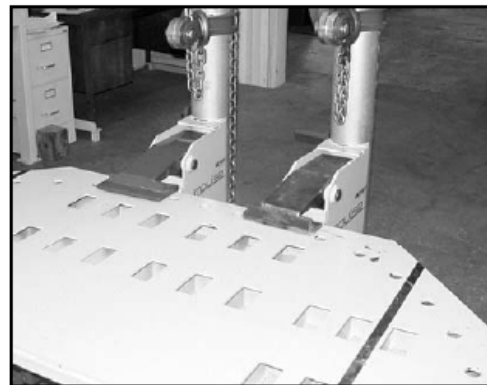

Figure 25



Figure 26

To Lower Machine For Loading

Important	Observe preceding precautions when lowering machine with vehicle aboard.
-----------	--

1. To keep towers clear of the floor during loading and unloading, position the towers at front of machine and secure "Sure-Lock" force clamps to front pinning holes. (See figure 25).
2. Install loading ramps at rear of machine (See figure 26)

NOTE:	Loading ramp slots must fully engage the pinning lugs at rear edges of machine. (See figure 26)
-------	---

3. Turn off all auxiliary line valves or disconnect all tower and auxiliary cylinders from system (See figure 27)
4. Turn lift switch on pump cabinet to "ON" position. (See figure 28)
5. Activate lock arm release by depressing and holding the brass button on the pump cabinet. (See figure 29)
6. Depress and hold the "UP" button on hand-held control pendant to raise the machine until both safety lock arms audibly release from their lock positions. (See figure 30)
7. While continuing to hold down the "UNLOCK" button, depress and hold the "DOWN" button on the hand-held control unit. The machine will automatically tilt into the loading position. (See figure 31)

CAUTION:

- Before lowering machine, clear all obstacles from under and around machine.
- DO NOT allow anyone or anything to ride on machine or be under machine during lowering procedures.



Figure 27



Figure 28



Figure 29



Figure 30



Figure 31

To Raise Machine After Loading

1. Turn off all auxiliary line valves or disconnect all tower and auxiliary cylinders from system (See figure 31)
2. Turn lift switch on pump cabinet to “ON” position. (See figure 32)
3. Activate pump by depressing and holding “UP” button on hand-held control pendant. (See figure 33). Rear end of deck will rise first until deck is level. Once deck is level, both ends will rise together.
4. After machine is slightly above desired working height, as indicated by the audible drop of both lock arms into their locking positions, release “UP” button on hand-held pendant.
5. Depress and hold “DOWN” button on hand-held pendant to lower machine into mechanical stops. (See figure 34).



CAUTION:

- Before raising machine, verify that vehicle’s emergency brake is set and automatic transmission is in park (if equipped)
- DO NOT walk behind machine during raising procedure.
- Install wheel chocks at front of front tire and rear of rear tire.



Figure 31



Figure 32



Figure 33



Figure 34

Adjust Working Height

The FUZION has four (4) working heights from 19 inches (480 mm) to 48 inches (1220 mm).

To Raise Machine Working Height

1. Turn off all auxiliary line valves or disconnect all tower and auxiliary cylinders from system. (See figure 35).
2. Turn lift switch on pump cabinet to “ON” position. (See figure 36).
3. Activate pump by depressing and holding “UP” button on hand-held control pendant. (See figure 37).
4. After machine is slightly above desired working height, as indicated by the audible drop of both lock arms into their locking positions, release “UP” button on hand-held pendant.
5. Depress and hold “DOWN” button on hand-held control pendant to lower machine into mechanical stops. (See figure 38).



Figure 35

To Lower Machine Working Height

1. Turn off all auxiliary line valves or disconnect all tower and auxiliary cylinders from system. (See figure 35).
2. Turn lift switch on pump cabinet to “ON” position. (See figure 36).
3. Activate lock arm release by depressing and holding the brass button on the pump cabinet (See figure 37).
4. Depress and hold the “UP” button on hand-held control pendant to raise the machine until both safety lock arms audibly release from their lock positions. (See figure 38)
5. While continuing to hold down the “UNLOCK” button, depress and hold the “DOWN” button on hand-held control pendant until machine is slightly above desired working height. (See figure 39).
6. Release “UNLOCK” button on pump cabinet to reengage safety lock arms. Continue to depress “DOWN” button on hand-held control pendant until machine settles in locks.



Figure 36

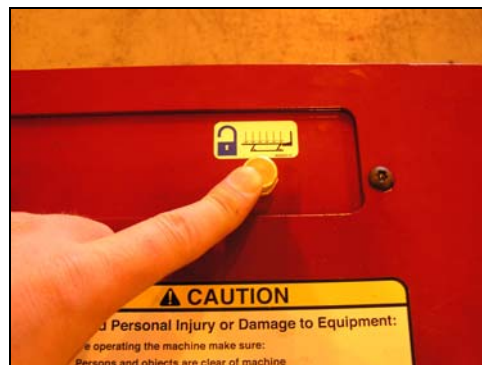

Figure 37



Figure 38



Figure 39

Rigid Crossmember

The rigid crossmember is used to maintain strength and rigidity of the deck any time the optional Shop Hopper is not docked.

If the yellow caution decal is visible, rigid crossmember must be installed and pinned in order to prevent irreparable damage to the deck during pulling. (see figures 40 and 41)



WARNING:

To avoid personal injury or damage to equipment,

- Rigid crossmember must be pinned in place when the Shop Hopper is removed
- Pulling without rigid crossmember or Shop Hopper in place will cause unreparable damage
- Always use an assistant when lifting or positioning the rigid crossmember.



Figure 40



Figure 41

Shop Hopper

General

The innovative Chief Shop Hopper trolley easily docks vehicles with the FUZION machine for heavy pulling, while allowing mobility for a variety of other non-pulling related work. (see figure 42)



CAUTION:

To avoid personal injury or damage to equipment,

ALWAYS:

- Use assistance when moving Shop Hopper or lifting anchoring crossbars
- Keep loads centered
- Apply wheel brakes when parked
- Have at least two casters installed from the side

NEVER:

- Park Shop Hopper on a slope
- Roll Shop Hopper sideways on a slope
- Install casters with all four on the ends

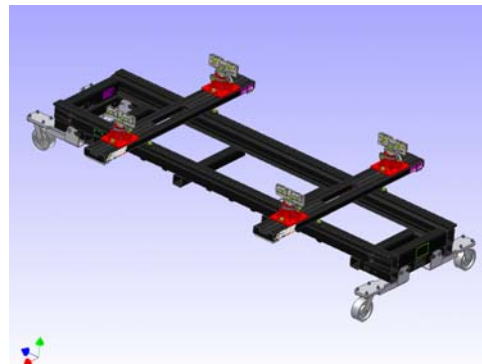

Figure 42



Figure 43

Parking

When the Shop Hopper is not in motion, apply the caster brakes. (see figure 43)

Docking

Docking is achieved by setting the FUZION deck in the first lock position. This position is set specifically for this purpose. When docking for the first time, check the position of the guide rollers on both the deck and the Shop Hopper and adjust as necessary to ensure each roller glides smoothly along the entire length of its mating surface. (see figures 44 and 45)

The docking end of the Shop Hopper is interchangeable. It is whichever end the removable casters are mounted in the narrow configuration.

! WARNING: To prevent personal injury or property damage never mount both sets of removable casters in the narrow configuration.

Roll the Shop Hopper into the FUZION machine. The three usable docking positions are: Shop Hopper touching front of deck, Shop Hopper flush with back end of deck, Shop Hopper centered between front and rear of deck.

When the deck is raised, the slots in the deck's lower ledge will automatically engage the tabs on the Shop Hoppers side rails.

! CAUTION: As deck is raised from the loading position, entire perimeter of Shop Hopper becomes a pinch point. Keep hands clear of perimeter during loading.

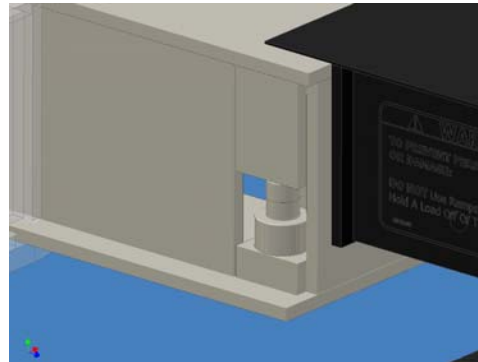

Figure 44



Figure 45

Undocking

Undocking is the reversal of docking except that prior to lowering the machine into the first lock position, the front casters of the shop hopper need to be rotated to their trailing position. (See figure 46) If the Shop Hopper is docked completely forward in the Fuzion this will not be necessary.

Failure to trail the casters will make it difficult or impossible to withdraw the Shop Hopper, and may cause the casters to bind against the lift mechanisms resulting in damage.

Optional Rolling Crossmember

The rolling crossmember is designed to roll freely along the track of the Shop Hopper under no load but then compress and lock in place under a load of 500 pounds or more. (See figure 47)

**CAUTION:**

- DO NOT use rolling crossmember as a step.
- DO NOT use rolling crossmember as a base to make a hydraulic push unless auxiliary ram is positioned perpendicular (90 degrees) to the top of the crossmember.
- DO NOT make angular pushes from the crossmember.

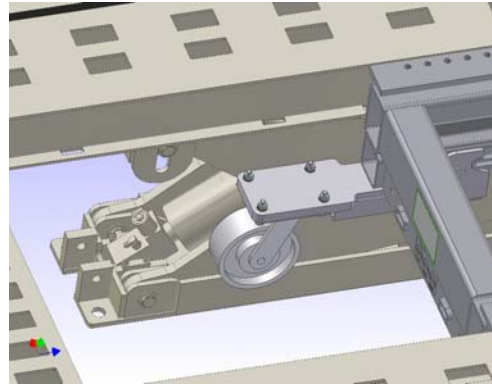

Figure 46

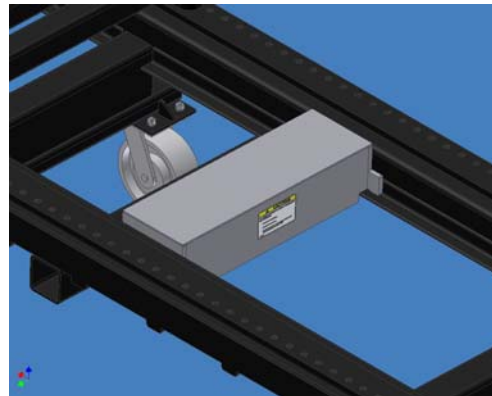

Figure 47

Shop Hopper Removable Casters

The removable casters of the Shop Hopper give three primary benefits. First, they allow the Shop Hopper to be docked with the Fuzion at both ends. Second, they allow the Fuzion to be lowered into the lowest position with the Shop Hopper docked. Third, they allow the Shop Hopper to sit on the floor when removed.

Removable Caster Mounting

The removable casters can be mounted from the ends and from the sides at both ends of the Shop Hopper. For normal use all casters should always be mounted from the sides for maximum stability. Mounting one pair from the end and the other pair from the side allows the Shop Hopper to be docked with the Fuzion.

WARNING: To prevent personal injury or property damage never mount both pairs of casters from the ends of the Shop Hopper. (See figure 47)

To remove the casters the Shop Hopper must first be raised at least 4 inches. Next, lock the swivel lock mechanism on the caster to be removed. Third, remove the hair pin clip from the retaining pin. (See figure 48) Then slightly lift the caster end of the mount and remove the pin at the same time. With the pin removed the mount will pivot down. (See figure 49) Continue to pivot the mount down and unhook the mount from the lock. The mount will then slide freely from the Shop Hopper. (See figure 50)

To install the casters, the Shop Hopper must be lifted at least 16" off the floor. Installation is similar to removal with some additional steps. First, determine the most likely use of the Shop Hopper. If it is to be docked with the Fuzion, pick which end will be to the front of the Fuzion. That end will have to have the casters mounted from the end. If the Shop Hopper is not likely to be docked, all casters should be mounted from the side for maximum stability. (See figure 47) After this has been done, the casters can be installed at the appropriate locations.

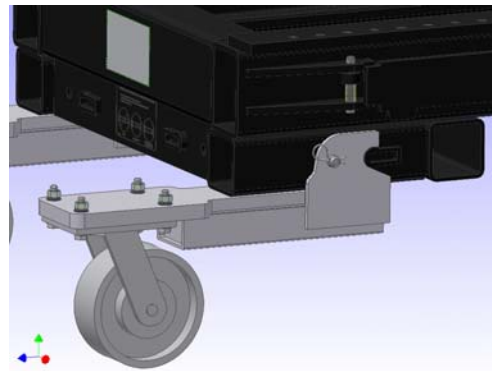

Figure 48

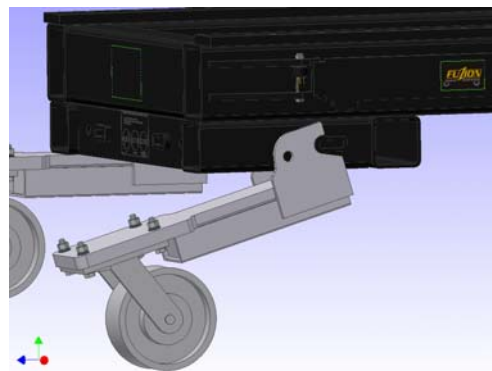

Figure 49

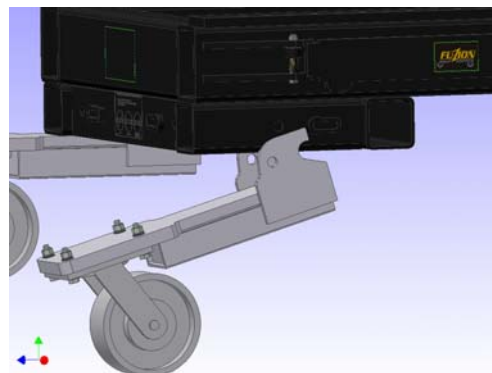

Figure 50

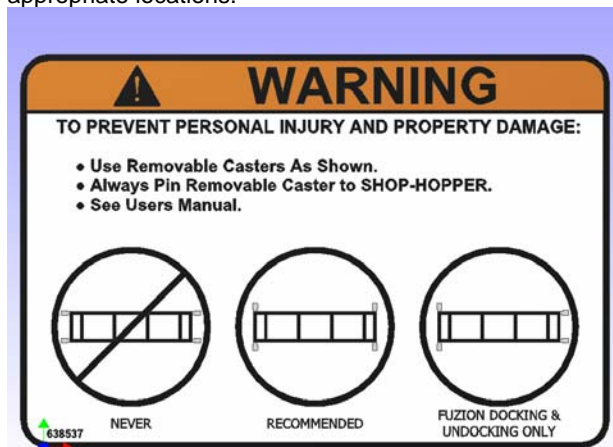

Figure 47

WARNING
To prevent personal injury and property damage. Always fully engage the pin and hair pin clip when installing the casters.

Shop Hopper Tower

The Shop Hopper tower is an optional accessory that allows light pulls to be done with the Shop Hopper away from the Fuzion. (See figure 51) This tower mates to any of the 12 square holes around the bottom of the Shop Hopper. In order to properly use the Shop Hopper tower, the tower must be fully inserted into one of the square holes. (See figure 52)



WARNING

To prevent personal injury and property damage. Always fully engage the Shop Hopper tower mount into the Shop Hopper before making any pulls.

Once engaged into the Shop Hopper, the tower may be pivoted in the mount to achieve the desired pulling angle. To do this, lift the spring loaded pull pin on the tower arm. (See figure 53) Next, rotate the tower and fully engage the pull pin into the desired location.

The pulling chain and collar work in a similar manner to the Fuzion towers. The Shop Hopper tower is hydraulically powered by an air over hydraulic pump. The pump must be connected to an air supply to function.

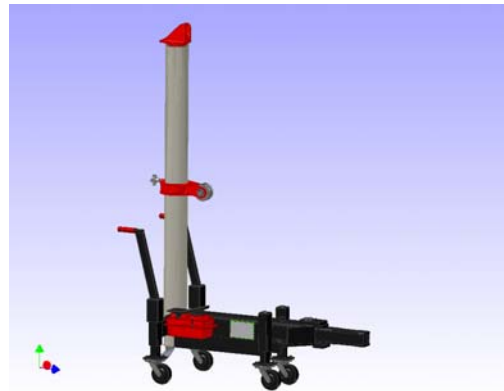

Figure 51

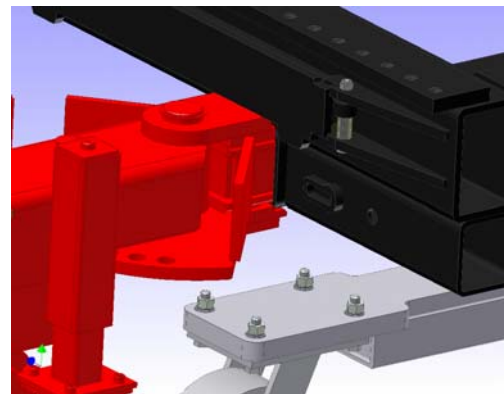

Figure 52

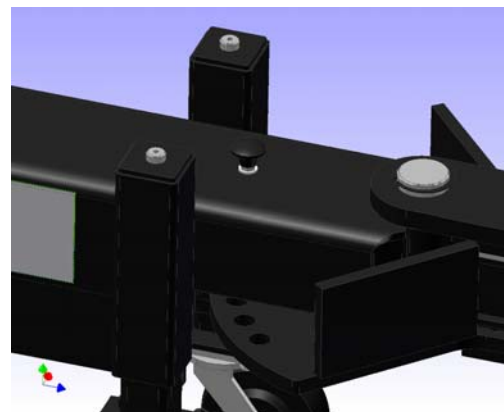

Figure 53

Shop Hopper Vehicle Anchoring

The Shop Hopper vehicle anchoring system consists of four anchoring stands with clamp bars and two cross bars. Together with the cross bars, the anchoring stands and clamp bars provide a positive means of securing a vehicle to the Shop Hopper.

Crossbar Mounting

The crossbars can be mounted anywhere along the Shop Hopper as needed for the vehicle mounting locations. Each crossbar has four bolt locations that must be used to securely mount to the Shop Hopper. (See figure 54) For easier alignment of the crossbars with the desired holes, use one of the pins from the anchoring stands as an alignment tool. Once the crossbars have been placed, firmly tighten the bolts with a 30mm wrench.

Anchoring Base Mounting

The anchoring stands are mounted to the crossbars. They can be mounted anywhere along the track that the bar will slide. (See figure 55) Once the anchoring stands have been placed, they also must be securely mounted by tightening the bolts with a 30mm wrench.

Two Piece Anchoring

The clamp bars mount to the adjustable height tube of the anchoring stand. This assembly is called Two Piece Anchoring. Each bar fits between the ears on top of the tube. The bars are secured with the bolt and nut at the center of the clamp and tightened with a 30mm wrench. (See figure 56) The advantage of the Two Piece Anchoring is that the clamp bars can be attached to the pinch welds of the vehicle first. Then the anchoring bases and crossbars can be positioned to mount to the clamps. This arrangement will make it easier to load a vehicle on the Shop Hopper using a 2-post lift.

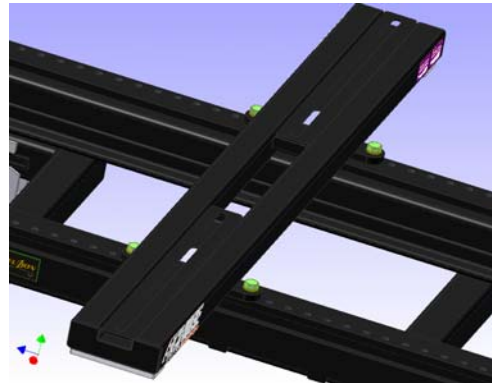

Figure 54

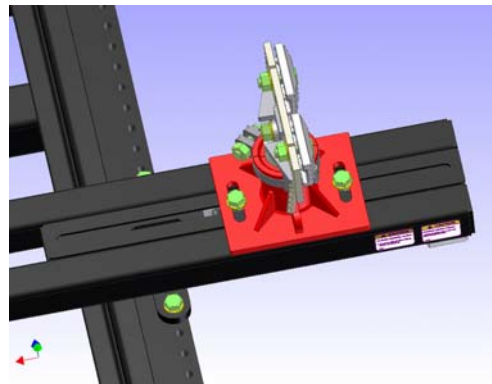

Figure 55

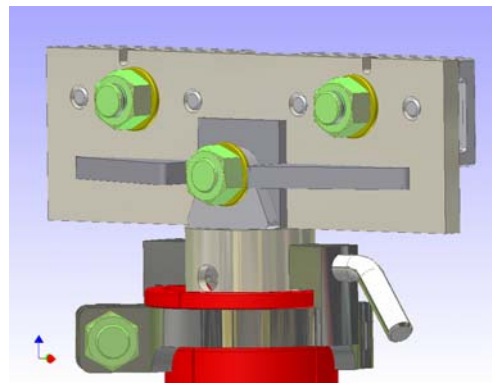

Figure 56

**CAUTION**

When making heavy pulls, tie the anchoring stands back to the deck using a chain and turnbuckle assist.

**WARNING**

To prevent personal injury and property damage. Always fully tighten all nuts and bolts when anchoring a vehicle before making any pulls.

Shop Hopper Crossbar Clamp

The Shop Hopper Crossbar Clamps are used when making pulls while the Shop Hopper is docked with the Fuzion. The clamps counter the lifting force of the tower and assure the Shop Hopper does not lift.

The crossbar clamps fit over the crossbars of the Shop Hopper and clamp around the Fuzion deck. (See figure 57)

To properly use the crossbar clamps they must be placed on the opposite side of the pull or across from the tower. (See figure 58) Place a clamp on each crossbar and fully tighten the screw knob at the bottom of the clamp.

If the pull needs to happen at the front of the Fuzion the clamps should both be put on the rear crossbar.

If the anchoring stands are out on the edge of the crossbars the crossbar clamps are still used. The clamps have a secondary raised area that is designed to go on top of the anchoring stands. Place the clamp on top of the anchoring stand next to the bolt head. (See figure 59)



CAUTION

Always install the Crossbar Clamps when making pulls with the Shop Hopper in the Fuzion deck.



Figure 57



Figure 58

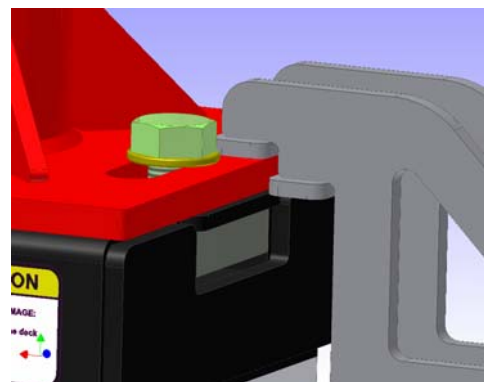



Figure 59

MACHINE MAINTENANCE

Check and Inspect

These components should be checked monthly and anytime a problem is suspected.

 **CAUTION:** To avoid personal injury when performing any maintenance function, always wear safety glasses and safety shoes.

Tower Chains, Tie-Down Chains

The tower chains/hooks and tie-down chains/hooks supplied with the Chief FUZION are high quality, high strength chains/hooks. If replacement is required, purchase only the original Chief product from an authorized Chief Automotive representative.

 **CAUTION:**

- DO NOT heat chain or hook while repairing vehicle – 600F (316C) of heat on chain will weaken it.
- DO NOT tip load chain hook. Tip loading chain hook will stress hook beyond its designed capability and could cause hook to fail.
- DO NOT pull with twisted chain links. Pulling with twisted chain links will stress chain links beyond their designed capability and could cause chain to fail.

Tower chains must be inspected for wear, nicks, gouges, stretched and bent links. If found, replace chain.

Tower chain hooks must be inspected for twist and stretched openings. If found, replace chain.

Loading Ramps

Inspect loading ramps making sure loading ramp slots fully engage the pinning lugs at rear of machine each time mainframe is raised or lowered.

Tower Rollers

Inspect inside and outside tower roller wheels for damage. The inside and outside roller bearings are lubrication free. Use compressed air to clean. DO NOT lubricate.

Power and Control Cords

Inspect power and control cords for worn insulation or other damage. If found, replace cord(s).

Cleaning and Lubricating

These components should be cleaned and lubricated as specified for trouble free operation and extended service. When lubricating use the following:

Oil – Use 30 weight motor oil for all components requiring lubricating oil.

Grease – Use a SUS750 lithium type grease such as lubriplate #630-2 for all components requiring grease

Tower Heads

Grease tower heads annually

1. Remove tower chain from tower head
2. Remove tower head from tower pipe
3. Clean dirt from tower head pipe and where tower head pipe rubs on inside of tower pipe.
4. Apply grease to tower head pipe
5. Reinstall tower head and tower chain

Collars

Clean and lubricate collars monthly.

1. Use compressed air to blow out dirt or dust that collects between collar ears and rollers.

 **CAUTION:** Wear safety glasses while using compressed air to blow out dirt and dust.

2. Place a few drops of oil on the roller pin between roller and collar ears (each side). Then turn roller a few times. Roller must turn freely

Eliminating Air in Hydraulic System

If hydraulic system is opened to replace a system component, it is necessary to bleed air from system prior to using it.

Bleeding Air in System at Tower Cylinder

1. Connect auxiliary line to tower cylinder and open auxiliary line valve.
2. Remove tower head and chain
3. Fully extend tower cylinder by depressing and holding "UP" button on hand-held pendant until tower gauge shows 5 tons of pressure on system.

Bleeding Air in System at Tower Cylinder (Continued)

4. While holding rag over the top of the cylinder to prevent oil spray, use a 3/16" T-handle allen wrench, loosen cylinder top bolt ½ turn.
5. Rapid, side-to-side motion of the T-handle may be necessary to unseat the seal washer at the top of the cylinder.

CAUTION: Wear safety glasses to protect eyes from hydraulic oil in the event it squirts past rag.

6. Trapped air or trapped air/oil mixture (indicated by foam in the oil) should escape from top of cylinder. Wipe up escaping oil with rag.
7. When cylinder is completely bled, only clean oil should escape from top of cylinder.

NOTE: It may be necessary to tighten top cylinder bolt and repressurize system to 5 tons and repeat procedure

8. Replace tower head and chain. Lower tower cylinder and refill reservoir to within 1" of fill port with all cylinders in retracted position.

Refill Hydraulic Fluid Reservoir

The hydraulic pump contains 2.9 gallons (11 liters) of hydraulic oil. When refilling or adding oil, fill to within 1" (25 mm) of fill port using SUS 215 viscosity @100°F (38°C) 10W hydraulic oil.

CAUTION: Fill pump reservoir with all cylinders retracted and deck in loading position.
DO NOT overfill pump reservoir.

Scissor Lift Assembly

All scissor lift pivot points are permanently lubricated and do not require maintenance except for occasional cleaning.

Outer Track

Using compressed air, blow dirt and debris from outer track. If necessary, use stiff brush to remove build up of dust and paint on outer track surface.

Visually inspect outer track for damage. Although small dents or upsets in the outer track may not affect the operation of the tower, they might indicate tower adjustment is necessary.

Sure Lock

With normal use, the pivots on the sure lock clamping system should stay free of dirt and operate smoothly and quietly. Extended periods of non-use or damp environments may adversely affect the operation of the sure lock.

Use compressed air to blow dirt and debris from sure lock pivot points. Apply a few drops of oil to sure lock pivot pin and handle shaft pivots and work mechanism.

NOTE: It may be necessary to remove the handle shaft retainer bolt and washer to lubricate both sides of the handle shaft. Refer to parts manual exploded view for details on removal of handle shaft retainer components.

CAUTION: Wear safety glasses while using compressed air to blow out dirt and dust.

The rotational motion of the sure lock handles is transmitted to the sure lock linkage via a ¼" key. The key is retained by a ¼-20 bolt. Verify that the bolt is tightened correctly.

Visually inspect the internal sure lock linkage to verify that the Tower Linkage Driver bar is centered on the sure lock handle shaft. With the sure lock clamp in the locked position, inspect that engagement of the tower float linkage bars to the handle shaft.

Tower Rollers

Using compressed air, blow dirt and debris from the tower outside wheel assemblies. Visually inspect the bolts retaining the outside wheels to the tower weldment and the outside roller guard for damage.

Verify that the four bolts retaining the tower hook to the inside end of the 360 tower are not loose. Verify that the two bolts holding the tower outrigger block are tight.

NOTE: Refer to Parts Manual for detailed exploded views of referenced parts. Contact Chief Automotive with any questions regarding the usage or maintenance of the FUZION system.

Machine Leveling

1. Position towers at front of machine and secure "Sure-Lock" force clamps to front pinning holes
2. With the machine still in the shipping legs, raise machine and insert shims(Figure 48) until the machine is level with the highest corner(Note: machine shown only has shims in three corners) (see Figure 49)
3. Verify that the dimension from the outside of one scissor base bottom plate to the other is 59 ¾ inches (See Figure 50).
4. Use the scissor base as a template and the base insert as a drill guide to install eight (8) concrete anchors (See Figure 47). See Anchoring section for more information
5. Move around the machine placing a level across the front, rear, and down both sides of the deck. The machine should be level in all working heights.
6. Adjust level by raising the scissors using the Shipping leg and adding shims (See figure 48 & 49). Repeat this process until the machine is level on all corners.
7. Once the machine is level, make sure the base inserts are in place and tighten the nuts on the concrete anchors. **DO NOT** use an impact wrench for tightening
8. Depending on how many shims where placed under the Fuzion, shims may need to be added to the Shop Hopper. Shims for the Shop Hopper are placed between the caster and the frame.

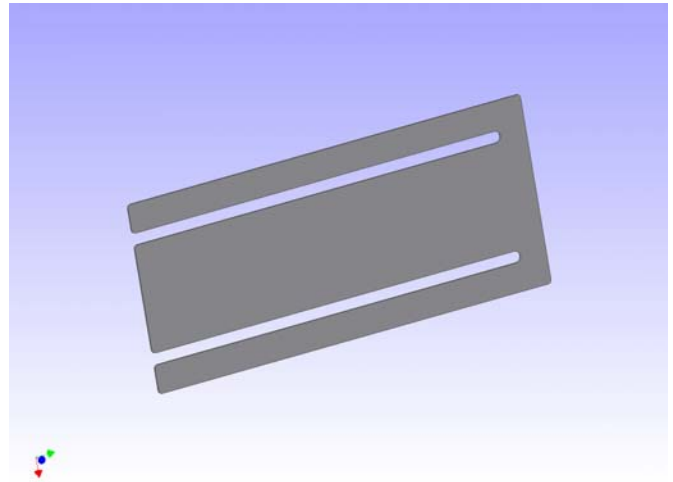

Figure 48

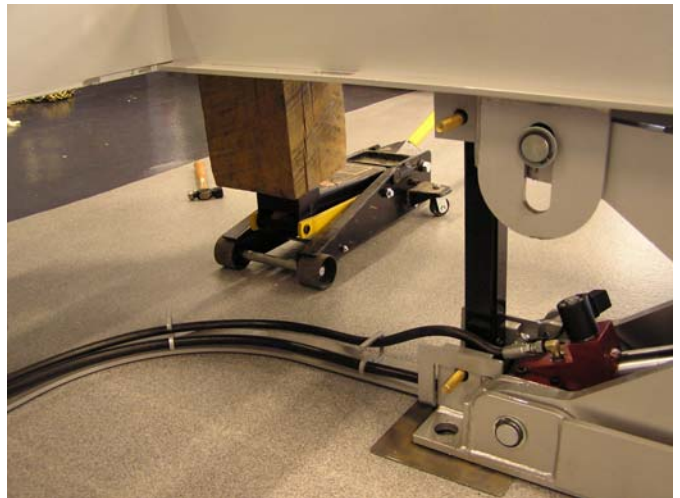

Figure 49



Figure 47

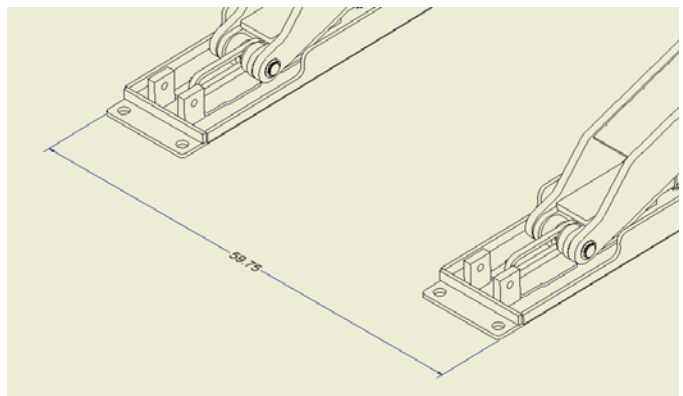

Figure 50

Machine Anchoring

1. Anchors must be installed at least 5-11/16" from any edge or seam in concrete.
2. The concrete must be at least 4-1/4" thick with a compressive strength of 3000psi.
3. Use a hammer drill with a carbide tip, 3/4" diameter solid drill bit. The bit tip diameter should be to ANSI Standard B95.12-1977 (.775" to .787").
4. Keep drill perpendicular to the floor while drilling. Let drill do the work. Drill the hole completely through the slab. Clean dust from hole. (See Figure 51)
5. Assemble the washers and nuts onto the anchor bolts. Thread the nuts onto the anchor bolts where the top of the nuts are just above the top of the bolts, as shown.
6. Using a hammer, carefully tap the anchor bolts into the concrete until the washer rests against the base plate. (See Figure 52)
7. If more than 2" of shimming is required, do not use the anchors and shims provided with the lift. Use longer anchors and fabricate larger shims from steel flat.
8. Once the machine is level, tighten the anchor bolts to 150 ft-lbs. Do not use an impact wrench on anchor bolts. (See Figure 53)

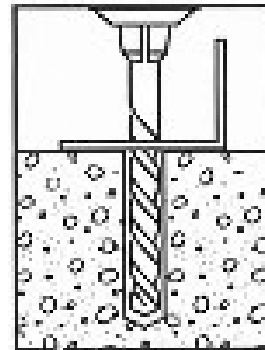

Figure 51

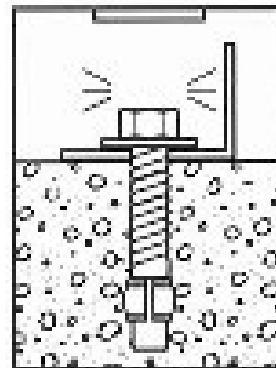

Figure 52

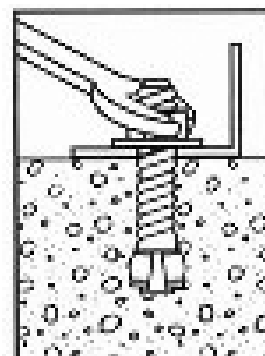

Figure 53

Troubleshooting		
PROBLEM	CAUSE	POSSIBLE SOLUTION
Pump will not Run	Power cord disconnected Power cord damaged Circuit breaker tripped or blown fuse Pendant not connected Damaged pendant cord Blown control board fuse Bad Pendant Bad motor start relay	Plug in power cord Inspect power cord for damage. Contact Chief Automotive service representative for repair or replacement if necessary Reset circuit breaker or replace fuse on circuit board inside cabinet Connect pendant to pump cabinet Inspect pendant cord for damage. Contact Chief Automotive service representative for repair or replacement if necessary. Remove and inspect fuse. Replace if necessary. Inspect pendant. Contact Chief Automotive Service representative for repair or replacement if necessary. Replace motor start relay. Contact Chief Automotive Service Representative for replacement.
Pump will not build pressure or builds pressure slowly	Hydraulic fluid low Contamination in control manifold startup valve Bad control manifold startup valve coil Contamination in pump unload valve	Fill fluid reservoir to within 1" (25 mm) of top with SUS215 viscosity @ 100°F (38C) 10W hydraulic oil with all cylinders down and machine in loading position. Remove and clean valve. Contact Chief Automotive Service Representative. Check for magnetic field at V4 coil. Contact Chief Automotive for replacement if necessary. (Refer to parts manual) Remove and inspect pump unload valve. (Refer to parts manual). Contact Chief Automotive service representative.
Pump will not hold pressure	Hydraulic oil leak Contamination in control manifold check valve Contamination in control manifold V3 valve Contamination in pump unload valve	Check hoses, fittings, and quick couplers for leaks. Tighten or replace if necessary Clean and inspect check valve. Replace if necessary. (refer to parts manual) Clean and inspect V3 valve. Replace if necessary. (refer to parts manual) Remove and inspect pump unload valve. (Refer to parts manual). Contact Chief Automotive service representative.
Pump stalls or will not start under pressure	Facility wiring inadequate Extension cord too long or wire gauge too small	Rewire facility to comply with local electrical code. Add dedicated line with 20 amp breaker. Use extension cord rated for 25 amps at 120 volts with ground wire up to 25 feet (7.5m) long. IMPORTANT: Extension cord use is not recommended. If used, extension cords must meet standards (listed above) and be used only on a short term basis
Tower cylinder jumps	Air in hydraulic system	Bleed hydraulic system
Tower cylinder will not extend	Auxiliary line valve closed Auxiliary line not connected to tower Lift switch turned on Pump will not build pressure	Open auxiliary line valve one turn Connect auxiliary line to tower Turn off lift switch See pump problems above
Tower cylinder will not retract	Auxiliary line valve closed Auxiliary line not connected to tower Contamination in control manifold unload valve Directional valve "DOWN" coil not working	Open auxiliary line valve one turn Connect auxiliary line to tower Clean and inspect V3 valve. Replace if necessary. (Refer to parts manual) Replace coil – Contact Chief Automotive service representative.

Troubleshooting (continued)

Lift will not raise	Lift Switch Off	Turn Lift Switch "ON"
	Auxiliary line valve open	Close all auxiliary line valves
	Too much weight	Adhere to 12,000lb total weight limit
	Cabinet to lift cylinder hydraulic hoses not connected	Connect hoses
	Lift cylinder bleed valves open	Close bleeder valves or plugs
	Pump not building pressure	See pump troubleshooting
Right side of machine will not raise	Contamination in left lift valve	Remove and inspect V1 valve. Contact Chief Automotive for repair or replacement if necessary
	Defective coil	Check for magnetic field at V1 coil. Contact Chief Automotive for replacement if necessary
Left side of machine will not raise	Contamination in right lift valve	Remove and inspect V2 valve. Contact Chief Automotive for repair or replacement if necessary
	Defective coil	Check for magnetic field at V2 coil. Contact Chief Automotive for replacement if necessary
Deck is out of level	Failure to completely engage both lock arms when settling machine into stops	Raise deck to next available working height until both locks fall audibly into place. Lower machine into stops to restore level. See section on rephasing of hydraulic system.
	Failure to completely disengage both lock arms prior to lowering machine	
Towers roll hard	Dirt on outer track	Clean outer track
	Dirt in outer tower roller bearings	Clean outer tower roller bearings
	Tower shimmed incorrectly	Re-shim tower – Contact Chief Automotive Service representative.
	Damaged inner roller	Replace inner roller – Contact Chief Automotive service representative.
	Damaged track	Repair track – Contact Chief Automotive service representative.
Sure-Lock difficult to engage	Dirt on deck	Clean deck
	Dirt in sure-lock pivots	Clean sure-lock pivots. Apply a few drops of oil to pivots and operate sure-lock mechanism.
	Sure-Lock out of adjustment	Re-shim sure-lock – Contact Chief Automotive service representative.
Sure-lock difficult to disengage	Dirt in sure-lock pivots	Clean sure-lock pivots. Apply a few drops of oil to pivots and operate sure-lock mechanism.
	Sure-Lock out of adjustment	Re-shim sure-lock – Contact Chief Automotive service representative
Collars jump under load	Improper fit between collar and tower pipe	Refit collar – Contact Chief Automotive service representative.
Shop Hopper will not dock	Deck too high	Lower deck into first lock position
	Deck and/or floor unlevel	Review supplemental section on setup and leveling procedures
Shop Hopper will not undock	Deck too high	Lower deck into first lock position
	Deck and/or floor unlevel	Review supplemental section on setup and leveling procedures
	Shop Hopper front casters binding against lift mechanisms	Raise machine, swivel casters to their trailing position in line with the Shop Hopper, lower machine and try again
Shop Hopper difficult to align when docking	Guide rollers on Shop Hopper and/or deck misadjusted	Adjust rollers up or down as required for proper contact with track using spacer collars provided



P.O. Box 1368
Grand Island, Nebraska 68802-1368
Phone: 308/384-9747
Fax: 308/384-8966

www.chiefautomotive.com

**Chief reserves the right to alter product specifications
and/or package components without notice.**