

KAHUNA

USERS MANUAL



TABLE OF CONTENTS

WARRANTY	2
GENERAL SAFETY INSTRUCTIONS	3
GENERAL SPECIFICATIONS	4
INSTALLATION.....	5
General Information	5
Machine Anchoring	5
Installation Test	6
OPERATING INSTRUCTIONS.....	7
Safety Procedures.....	7
Daily Pre-Operation Check	8
Controls	9
Operation	10
Owner/Employer Responsibilities:	12
Lift Lockout/Tagout Procedure	13
Raising Vehicle.....	15
Lowering Vehicle.....	16
Anchoring Vehicle (Short Stands)	17
Anchoring Vehicle (Optional Tall Stands & Wheel Stands).....	18
Vector Pulling	20
Attaching the Vector Pulling Arm to the Deck	20
Basic Pulling Setup	20
Pulling Setup Examples	22
Foot Pump Assembly	23
MAINTENANCE	24
Periodic Maintenance Schedule.....	24
Daily Pre-Operation Check	24
Monthly Maintenance.....	24
Chain Maintenance.....	25
Refilling Hydraulic Fluid Reservoirs	25
Priming the Foot Pump.....	26
TROUBLESHOOTING	27

CHIEF'S LIMITED ONE-YEAR WARRANTY & LIABILITY

Chief Automotive Technologies warrants for one year from date of installation and/or purchase any of its products which do not perform satisfactorily due to defect caused by faulty material or workmanship. Chief's obligation under this warranty is limited to the repair or replacement of products which are defective and which have not been misused, carelessly handled, or defaced by repair or repairs made or attempted by others.

CHIEF AUTOMOTIVE TECHNOLOGIES DOES NOT ASSUME RESPONSIBILITY FOR ANY DEATH, INJURY OR PROPERTY DAMAGE RESULTING FROM THE OPERATOR'S NEGLIGENCE OR MISUSE OF THIS PRODUCT OR ITS ATTACHMENTS. CHIEF MAKES NO WRITTEN, EXPRESS OR IMPLIED WARRANTY WHATSOEVER OF MERCHANTABILITY OR FITNESS FOR A PARTICULAR PURPOSE OR OTHERWISE REGARDING THE EQUIPMENT OR ANY PART OF THE PRODUCT OTHER THAN THE LIMITED ONE-YEAR WARRANTY STATED ABOVE.

GENERAL SAFETY INSTRUCTIONS

This summary describes physical and chemical processes that may cause injury or death to personnel, or damage to equipment if not properly followed. This safety summary includes general safety precautions and instructions that must be understood and applied during operation and maintenance to make sure that personnel safety and protection of equipment is observed. Prior to performing any task, the WARNINGS, CAUTIONS, and NOTES included in that task should be reviewed and understood.

Warnings, Cautions, and Notes

WARNINGS and CAUTIONS are used in this manual to highlight operating or maintenance procedures, practices, conditions or statements that are considered essential to protection of personnel (WARNING) or equipment (CAUTION). WARNINGS or CAUTIONS immediately precede the step or procedure to which they apply. NOTES are used in this manual to highlight operating or maintenance procedures, practices, conditions or statements that are not essential to the safeguarding of personnel or equipment. NOTES may precede or follow the step or procedure, depending on the information to be highlighted. The Headings used and their definitions are as follows.

WARNING

Highlights essential operating or maintenance procedure, practice, condition, statement, etc. that if not strictly observed, could result in injury to, or death of, personnel or long term health hazards.

CAUTION

Highlights essential operating or maintenance procedure, practice, condition, statement, etc. that if not strictly observed, could result in damage to, or destruction of equipment.

NOTE:

Highlights essential operating or maintenance procedure, practice, condition, or statement.

GENERAL SPECIFICATIONS

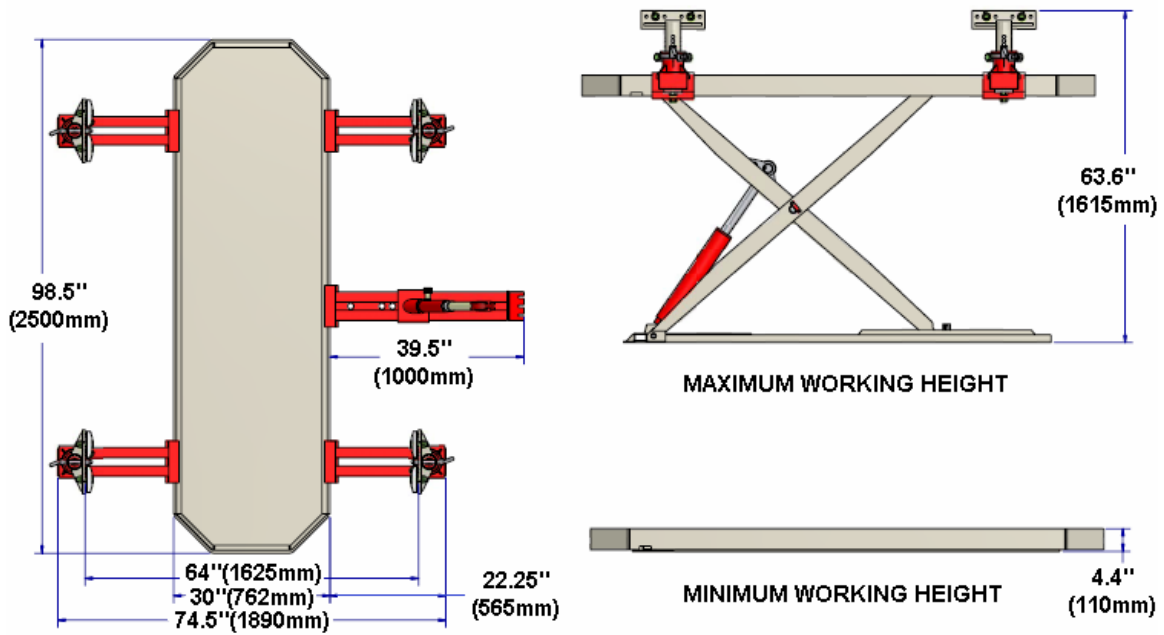

Hydraulic Pressure:	3,600 psi (250 bar)
Air Pressure:	100 psi (7 bar)
Max. Lift Capacity:	5,500 lbs (2,500 kg)
No. of Working Heights:	8
Machine Weight:	1,800 lbs (816 kg)
Power - U.S.:	120V/60Hz/20A
Power - International:	220V/50Hz/10A

INSTALLATION

General Information

1. Any freight damage must be noted on the freight bill before signing and reported to the freight carrier with a freight claim established. Identify the components and check for shortages. If shortages are discovered, contact your distributor immediately.
2. Consult building owner and / or architect's plans when applicable to establish the best lift location. The lift should be located on a relatively level floor with 4 in. minimum thickness, 3000-psi concrete slab that has been properly cured.
3. Make sure that the area where the lift will be located is free of obstructions for 12 ft. above the floor. This includes heaters, building supports, conduits, etc.
4. Make sure there is adequate space to allow movement around the lift with a vehicle in place.

Machine Anchoring

1. Anchors must be installed at least 5-11/16" from any edge or seam in concrete.
2. The concrete must be at least 4" thick with a compressive strength of 3000psi.
3. Use a hammer drill with a carbide tip, 3/4" diameter solid drill bit. The bit tip diameter should be to ANSI Standard B95.12-1977 (.775" to .787").

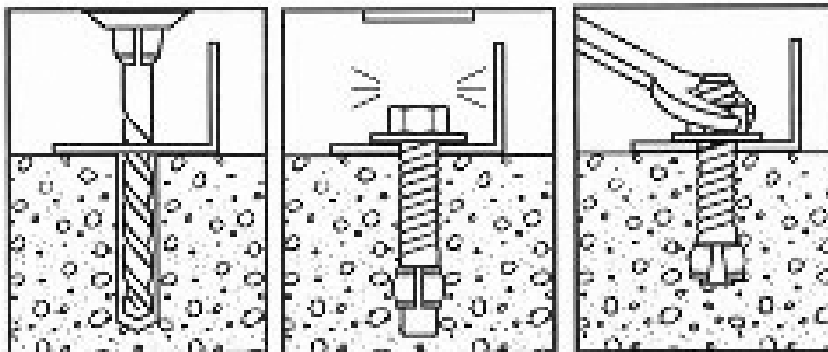

Fig. 1

Fig. 2

Fig. 3

4. Keep drill perpendicular to the floor while drilling. Let drill do the work. Drill the hole completely through the slab or a minimum 5 inches deep. Clean dust from hole. (See Figure 1)
5. Using a hammer, carefully tap the anchor bolts into the concrete until the washer rests against the base plate. (See Figure 2)
6. Tighten the anchor bolts to 95 to 120 ft-lbs. Do not use an impact wrench on anchor bolts. (See Figure 3)

Installation Test

Test the Lift operation by doing the following (requires a vehicle on the lift):

1. Push “up” switch to a position where the vehicle is just leaving the ground.
2. Raise lift only HALF WAY then lower completely at least one dozen times.
3. Raise lift to its extreme position and inspect. Make sure that there are no hydraulic leaks. Test mechanical locks. Make sure that the lift holds vehicle in steady position without lowering.
4. Raise lift slightly and push lock release button. Check that lift lowers smoothly and at a safe speed.
5. Repeat above procedures to make sure that lift is operating normally.

NOTE: During the initial testing, the lift will descend slowly. This is normal. It helps to add a payload, no greater than 500 pounds to help speed up the decent during this process.

6. Check all hoses for leaks. Tighten if necessary.

OPERATING INSTRUCTIONS

Safety Procedures

⚠ WARNING Failure to adhere to the following can result in death or injury, or damage to the equipment and vehicle. All personnel will be made aware of this warning and trained in the use and care of the lift.

1. Never allow unauthorized persons to operate lift. Thoroughly train new employees in the use and care of lift.
2. Lift should only be operated on a level foundation.
3. Caution - the power unit operates at high pressure.
4. Remove passengers before raising vehicle.
5. Prohibit unauthorized persons from being in shop area while lift is in use.
6. Do not exceed the lift's capacity.
7. Prior to lifting vehicle, walk around the lift and check for any objects that might interfere with the operation of lift, such as tools, air hoses, and shop equipment. Remove any potential obstacles that might impede roller travel.
8. Always lift vehicle using all four pads.
9. Never use lift to raise one end or one side of vehicle.
10. Raise vehicles about three inches and check stability by rocking.
11. Always lock the lift before going under the vehicle. Never allow anyone to go under the lift when raising or lowering.
12. The vehicle's center of gravity should be balanced on the lift.
13. Do not remove heavy components from a raised machine or vehicle without first installing adequate supports. The vehicle may become unbalanced and fall.

Daily Pre-Operation Check (8-Hours)

NOTE: Occupational Safety and Health Administration (OSHA) and the American National Standards Institute (ANSI) require users to inspect lifting equipment at the start of every shift. These and other periodic inspections are the responsibility of the user.

⚠ WARNING Failure to perform the daily pre-operational check can result in expensive property damage, lost production time, serious personal injury, and even death. The safety latch system must be checked and working properly before the lift is put to use.

The daily pre-operational check consists of the following:

1. Check hydraulic connections, and hoses for leakage.
2. Make sure all bolts are secured and snug with lock washer, nylon lock nuts, or cotter keys.
3. Test the lift locking mechanism for proper operation.
4. Check oil level in pump reservoir.
5. Always keep the lift platforms clean and do not use the lift if it has oil, dirt or mud on it.

Controls

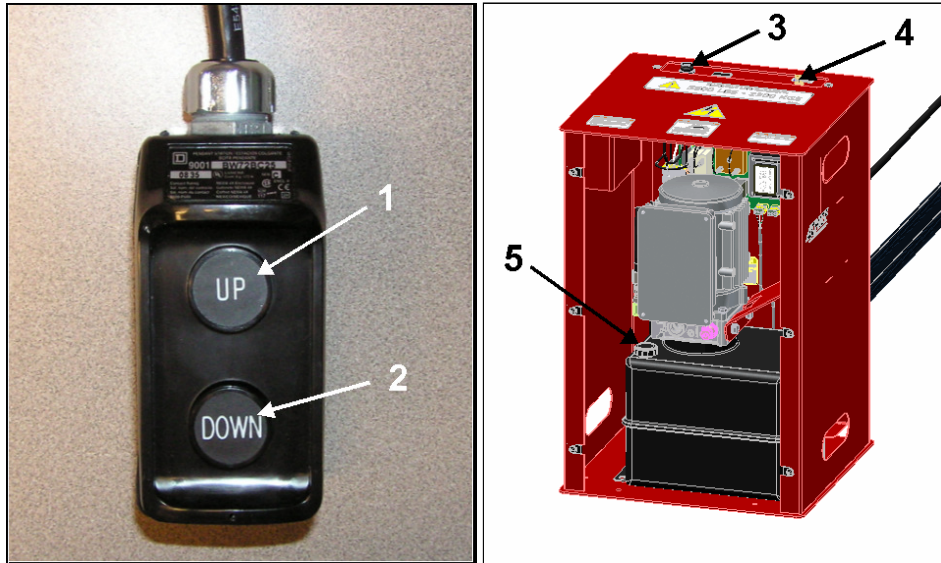

Controls		
Item No.	Type	Purpose
1	Push Button Switch	Used to start the pump and raise the lift when pressed down. (Raises vehicle)
2	Push Button Switch	Used to relieve hydraulic pressure when pressed down. (Lowers vehicle)
3	Rocker Switch	Controls electrical power to the power unit. Lights when on.
4	Push Button	Pneumatic control used to disengage the safety lock prior to lowering the lift.
5	Reservoir Cap	Cap for the power unit fluid reservoir. Remove to add fluid.

Operation

Operate the lift as given in the following paragraphs.

SAFETY WARNING LABELS FOR HINGED FRAME ENGAGING LIFTS

Lift Owner/User Responsibilities:

A. This Safety Warning placard **SHALL** be displayed in a conspicuous location in the lift area.

B. Use one of the mounting arrangements illustrated on back of this placard.

C. These Safety Warning labels supplement other documents supplied with the lift.

D. Be certain all lift operators read and understand these labels, operating instructions and other safety related information supplied with the lift.

 <p style="text-align: center;">⚠ WARNING</p> <p style="text-align: center;">Position vehicle with center of gravity midway between adapters. ©</p>	 <p style="text-align: center;">⚠ WARNING</p> <p style="text-align: center;">Remain clear of lift when raising or lowering vehicle. ©</p>	 <p style="text-align: center;">⚠ WARNING</p> <p style="text-align: center;">Keep feet clear of lift while lowering. ©</p>
 <p style="text-align: center;">⚠ WARNING</p> <p style="text-align: center;">Clear area if vehicle is in danger of falling. ©</p>	 <p style="text-align: center;">⚠ WARNING</p> <p style="text-align: center;">Avoid excessive rocking of vehicle while on lift. ©</p>	 <p style="text-align: center;">⚠ WARNING</p> <p style="text-align: center;">Keep clear of pinch points when lift is moving. ©</p>

www.autolift.org

Safety label artwork courtesy of Automotive Lift Institute – www.autolift.org



Safety label artwork courtesy of Automotive Lift Institute – www.autolift.org

The Owner/Employer:

- Shall ensure that lift operators are qualified and that they are trained in the safe use and operation of the lift using the manufacturer's operating instructions; ALI/SM01-1, ALI Lifting it Right safety manual; ALI/ST-90 ALI Safety Tips card; ANSI/ALI ALOIM-2000, American National Standard for Automotive Lifts-Safety Requirements for Operation, Inspection and Maintenance; ALI/WL Series, ALI Uniform Warning Label Decals/Placards; and in the case of frame engaging lifts, ALI/LP-GUIDE, Vehicle Lifting Points/Quick Reference Guide for Frame Engaging Lifts.
- Shall establish procedures to periodically inspect the lift in accordance with the lift manufacturer's instructions or ANSI/ALI ALOIM-2000, American National Standard for Automotive Lifts-Safety Requirements for Operation, Inspection and Maintenance; and The Employer Shall ensure that lift inspectors are qualified and that they are adequately trained in the inspection of the lift.
- Shall establish procedures to periodically maintain the lift in accordance with the lift manufacturer's instructions or ANSI/ALI ALOIM-2000, American National Standard for Automotive Lifts-Safety Requirements for Operation, Inspection and Maintenance; and The Employer Shall ensure that lift maintenance personnel are qualified and that they are adequately trained in the maintenance of the lift.
- Shall maintain the periodic inspection and maintenance records recommended by the manufacturer or ANSI/ALI ALOIM-2000, American National Standard for Automotive Lifts-Safety Requirements for Operation, Inspection and Maintenance.
- Shall display the lift manufacturer's operating instructions; ALI/SM 93-1, ALI Lifting it Right safety manual; ALI/ST-90 ALI Safety Tips card; ANSI/ALI ALOIM-2000, American National Standard for Automotive Lifts-Safety Requirements for Operation, Inspection and Maintenance; and in the case of frame engaging lifts, ALI/LP-GUIDE, Vehicle Lifting Points/Quick Reference Guide for Frame Engaging Lifts; in a conspicuous location in the lift area convenient to the operator.
- Shall provide necessary lockout/tagout means for energy sources per ANSI Z244.1-1982 (R1993), Safety Requirements for the Lockout/Tagout of Energy Sources, before beginning any lift repairs.
- Shall not modify the lift in any manner without the prior written consent of the manufacturer.

Lift Lockout/Tagout Procedure

Purpose

This procedure establishes the minimum requirements for the lockout of energy that could cause injury to personnel by the operation of lifts in need of repair or being serviced. All employees shall comply with this procedure.

Responsibility

The responsibility for assuring that this procedure is followed is binding upon all employees and service personnel from outside service companies (i.e., Authorized Installers, contractors, etc.). All employees shall be instructed in the safety significance of the lockout procedure by the facility owner/manager. Each new or transferred employee along with visiting outside service personnel shall be instructed by the owner/manager (or assigned designee) in the purpose and use of the lockout procedure.

Preparation

Employees authorized to perform lockout shall ensure that the appropriate energy isolating device (i.e., circuit breaker, fuse, disconnect, etc.) is identified for the lift being locked out. Other such devices for other equipment may be located in close proximity of the appropriate energy isolating device. If the identity of the device is in question, see the shop supervisor for resolution. Assure that proper authorization is received prior to performing the lockout procedure.

Sequence of Lockout Procedure

- 1) Notify all affected employees that a lockout is being performed and the reason for it.
- 2) Unload the subject lift. Shut it down and assure the disconnect switch is "OFF" if one is provided on the lift.
- 3) The authorized lockout person operates the main energy isolation device removing power to the subject lift.
 - If this is a lockable device, the authorized lockout person places the assigned padlock on the device to prevent its unintentional reactivation. An appropriate tag is applied stating the person's name, at least 3" x 6" in size, an easily noticeable color, and states not to operate device or remove tag.
 - If this device is a non-lockable circuit breaker or fuse, replace with a "dummy" device and tag it appropriately as mentioned above.
- 4) Attempt to operate lift to assure the lockout is working. Be sure to return any switches to the "OFF" position.

Restoring Equipment to Service

- 1) Assure the work on the lift is complete and the area is clear of tools, vehicles, and personnel.
- 2) At this point, the authorized person can remove the lock (or dummy circuit breaker or fuse) & tag and activate the energy isolating device so that the lift may again be placed into operation.

Rules for Using Lockout Procedure

Use the Lockout Procedure whenever the lift is being repaired or serviced, waiting for repair when current operation could cause possible injury to personnel, or for any other situation when unintentional operation could injure personnel. No attempt shall be made to operate the lift when the energy isolating device is locked out.

Raising Vehicle

Raise the vehicle as follows:

1. Drive vehicle onto the lift and check if the vehicle is placed in appropriate position. Relocate vehicle as required.

NOTE: Some vehicles may have the manufacturer's Service Garage Lift Point locations identified by triangle shape marks on it's undercarriage (reference ANSI/SAE J2184-1992). Also, there may be a label located on the right front door lock face showing specific vehicle lift points. If the specific vehicle lift points are not identified, refer to the "Typical Lift Points" illustrated herein or the ANSI/ALI Lifting Point Guide included with your lift. ALWAYS follow the operating instructions supplied with the lift.

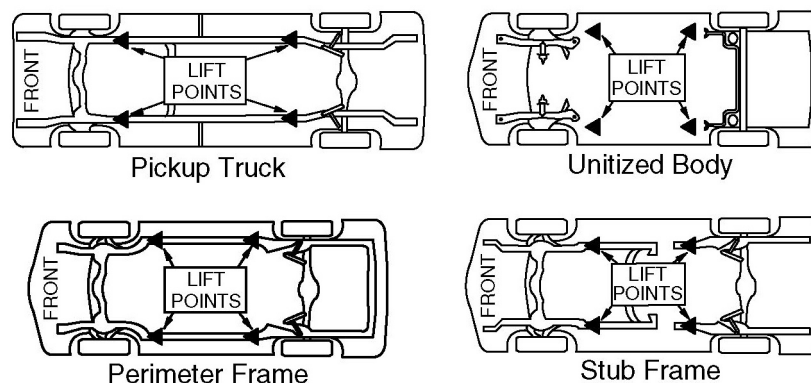

Typical Lift Points Diagram

2. Position the four lift arms at the appropriate places on the deck to allow the arms and pads to swing underneath the lifting points.
3. Locate lift pads at appropriate lifting points under vehicle.
4. Push "up" switch until the lift reaches a position to where the vehicle is just leaving the ground.
5. Inspect to make sure there is no interference with any other objects.
6. Check proper engagement of lifting pads on vehicle. Make sure that vehicle is horizontal on lift.
7. Shake moderately at front or rear bumper.
8. Raise vehicle to desired height then lower onto lock. Make sure that the lift holds the vehicle in steady position without lowering.

⚠ WARNING Failure to heed the following step can result in serious personal injury.

9. Disconnect electrical power to make sure lift is not inadvertently activated while working on vehicle.

Lowering Vehicle

Lower the vehicle by doing the following:

1. Prior to lowering vehicle, walk around the lift and check for any objects that might interfere with the operation of lift such as tools, air hoses, and shop equipment.
2. Reconnect electrical power to the power unit.
3. Raise lift slightly and push lock release button.
4. Check that lift lowers smoothly and at a safe speed.
5. Allow the lift to fully lower and lock the lift.
6. Swing the arms out of the way and slowly drive the vehicle out. Have some one outside the vehicle guide the driver.

Anchoring Vehicle (Short Stands)

1. Position the vehicle over the lift with the vehicle's center of gravity centered over the lift.

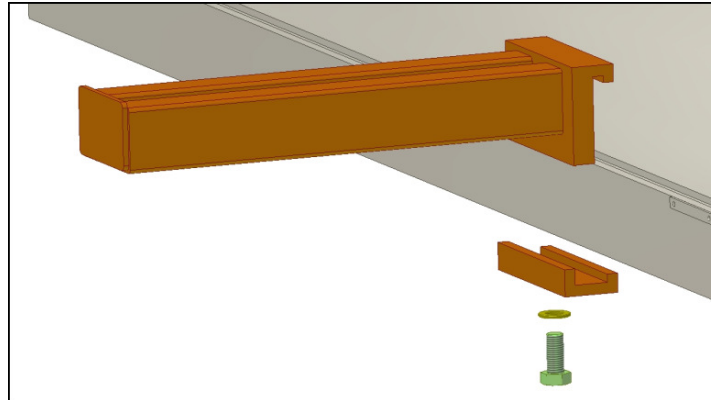

2. Place the anchoring arms on the deck directly below the desired anchoring points.

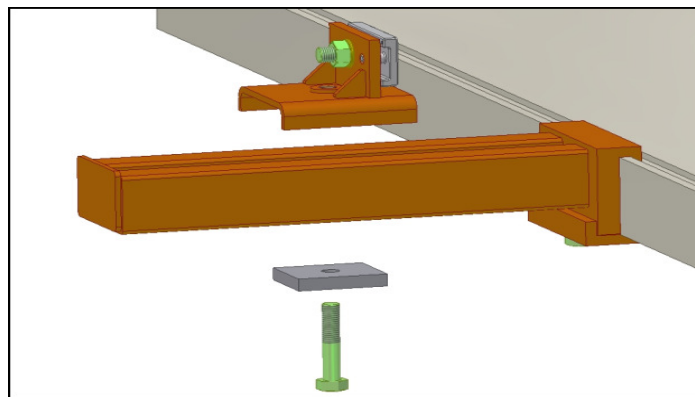

3. Position the short anchoring assemblies on the anchoring arms.
4. Raise the lift just high enough for the pinchwelds to settle into the clamps. Tighten the pinchweld clamps.
5. Raise the lift just high enough to be able to bolt the anchor assemblies to the anchoring arms. Secure the anchor assemblies to the anchoring arms with the plate and bolt provided.
6. Secure the anchoring arms to the deck with the brackets and bolts provided.

⚠ CAUTION Do not raise the lift to working heights without fully securing the anchoring components to the deck.

7. Reverse the previous steps to remove the vehicle from the lift.

Anchoring Vehicle (Optional Tall Stands & Wheel Stands)

1. Position the vehicle over the lift with the vehicle's center of gravity centered over the lift.
2. Follow the lift procedures in this manual to raise the vehicle.

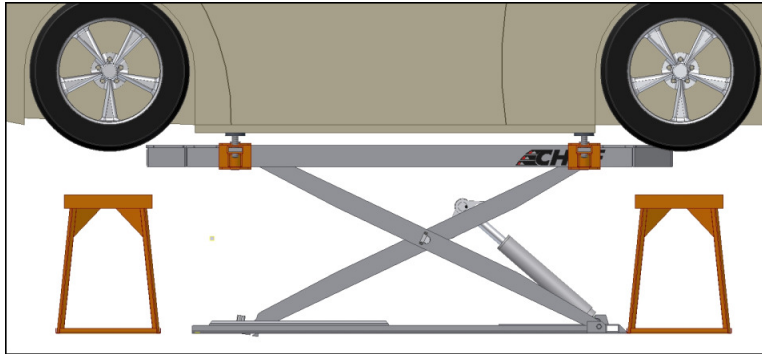

3. Raise the vehicle just high enough to slide the optional wheel stands under each tire.

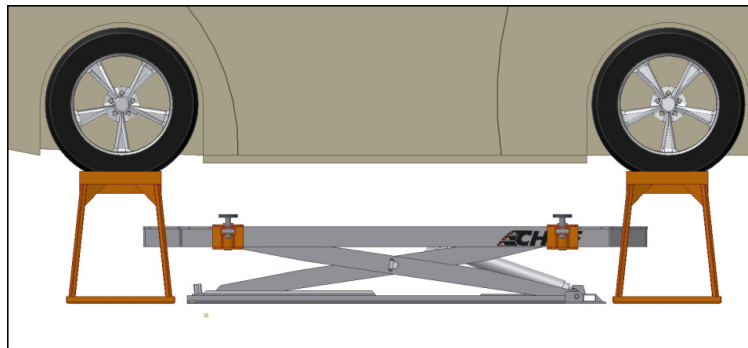

4. Lower the lift until the wheel stands are supporting the vehicle. Be sure that the load on the wheel stands is stable before lowering the lift further.
5. Remove the lift arms from the deck of the machine.

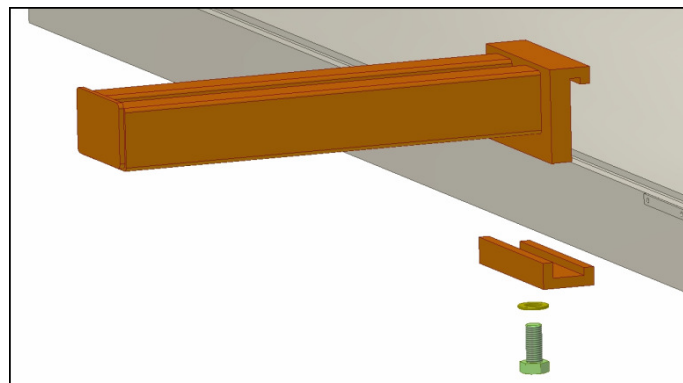

6. Determine the four points where the vehicle will be anchored and install the anchoring arms on the deck below those points. Be sure to secure the anchoring arms to the deck with the brackets and bolts provided.

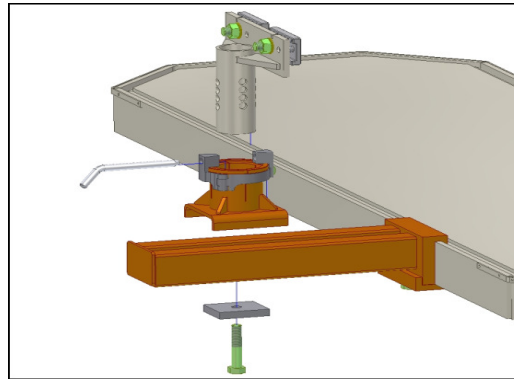

7. With the clamp tube pinned in the lowest position, install the optional tall anchoring stands on the anchoring arms. Do not tighten the bolt securing the stand to the arm.

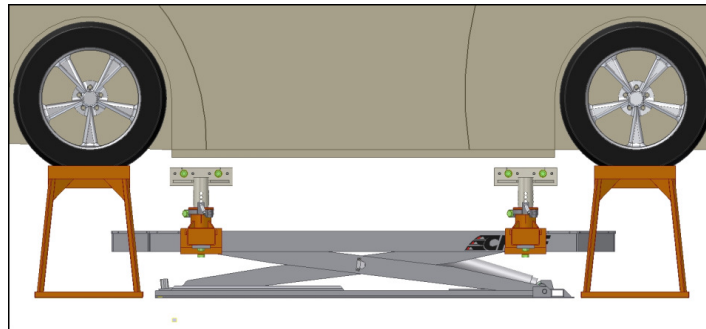

8. Raise the lift until the stands are just below the anchoring points on the vehicle.
9. Unpin the anchoring tubes. Raise the tubes and tighten the clamps.
10. Raise or lower the lift as needed to pin the anchoring tubes at the desired height.

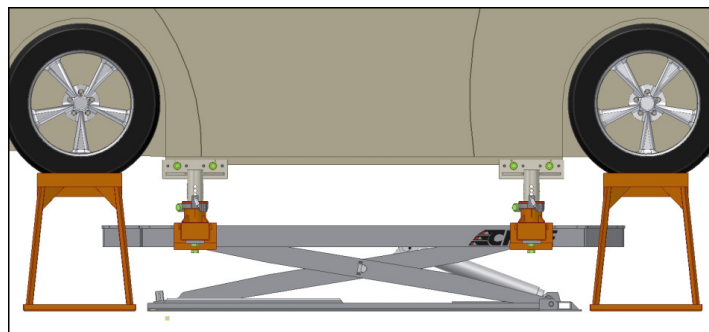

11. Raise the lift until the anchoring stands start to support the weight of the vehicle. Tighten the bolts securing the stands to the arms.
12. Raise the vehicle off the wheel stands and remove the wheel stands. Be sure that the lift lock has been fully seated in one of the locking positions before working on the vehicle.
13. Reverse the previous steps to remove the vehicle from the lift.

Vector Pulling

Attaching the Vector Pulling Arm to the Deck

The vector pulling arm may be attached anywhere on the outer edge of the deck. The arm pivots with respect to the deck to achieve virtually any pulling angle.

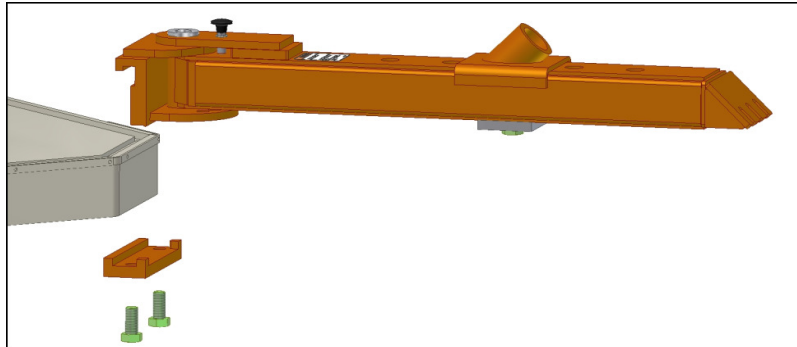

1. Determine where and at what angle the pull is to be made. Hang the pulling arm on the edge of the deck in a location that will produce the desired pull. Secure the pulling arm to the deck with the bracket and bolts provided.
2. Pivot the pulling arm to the desired angle by pulling up on the spring loaded pin. Be sure that the pin has fully engaged in the desired pinning location prior to proceeding.

Basic Pulling Setup

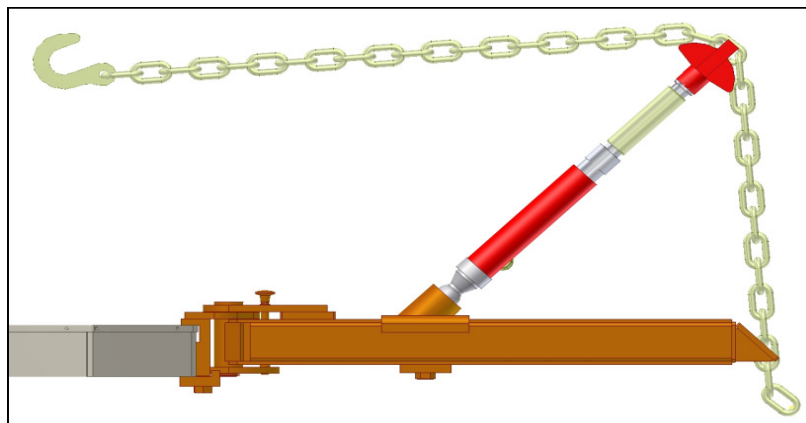

1. Prior to usage, make sure male and female quick couplers are free of dirt and other contamination. Assembly of the hydraulic pneumatic foot pump is covered later in this section.

⚠ CAUTION When disconnecting hydraulic hose from quick coupler, some fluid spillage may occur. To avoid personal injury or damage to property, always clean up any hydraulic fluid spillage from floor or work area.

2. Attach the male quick coupler on the hose from the foot pump to the female quick coupler on the ram making sure they are threaded tight.

NOTE: Quick couplers must be fully tightened to allow flow of hydraulic oil to auxiliary ram.

3. Attach pulling chain to vehicle.
4. Secure auxiliary pulling head to the ram.
5. Mount the ram base in the proper location on the vector pulling arm and secure it to the ram with the bolt and plate. Insert the ball on the end of the ram into the ram base.
6. Determine the correct height and angle for the pull. Position the chain on the auxiliary pulling head and secure it with the pin.

NOTE: If more height is needed, add extension coupling and extension tube to assembly.

7. Secure tail of chain to the end of the vector pulling arm.

⚠ WARNING DO NOT position yourself close to, or in line with chains, clamps, or other accessories while pressure is applied to this system. Failure to observe this warning could result in operator injury due to the possibility of a chain or accessory disengaging or failing while pressure is applied to this system.

⚠ CAUTION Normal working range for 3/8" tie down chain is 500 to 3,650 psi (35 to 250 bar) on pressure gauge with applied force to the chain of 7,400 lbs (33 kN). Proof test on this chain is 20,000 lbs (90 kN).

⚠ CAUTION DO NOT heat chain or hook while repairing vehicle - 600°F (316°C) of heat on chain will weaken it.

⚠ CAUTION DO NOT tip load chain hook. Tip loading chain hook will stress hook beyond its designed capability and could cause hook to fail.

⚠ CAUTION DO NOT pull with twisted chain links. Pulling with twisted chain links will stress chain links beyond their designed capability and could cause chain to fail.

⚠ CAUTION To prevent damage to foot pump and hydraulic ram, DO NOT operate pump when ram is fully extended.

8. Apply just a small amount of pressure and check that the pulling setup is correct. If it is not, release pressure and reposition.
9. Proceed with the pull.

Pulling Setup Examples

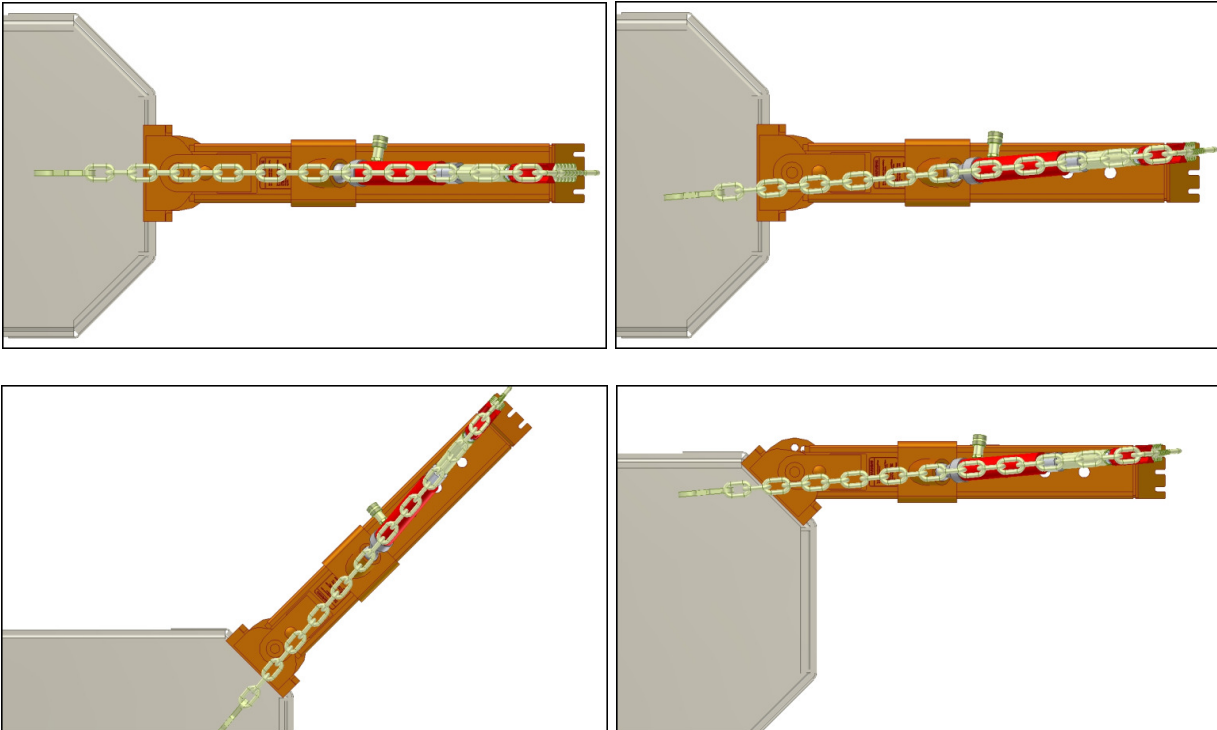

The drawings show examples of different ways in which vector pulls may be setup. To get different angles, the arm may be pivoted as shown, and/or the arm may be relocated anywhere around the deck. Slight angle adjustments can be made by hooking the chain in one of the outer slots in the end of the pulling arm as shown. In all cases, the chain and the auxiliary ram assembly must be in line with each other as shown.

NOTE: Tail end of pulling chain and its point of attachment to vector pulling arm must be in line with auxiliary ram assembly.

Foot Pump Assembly

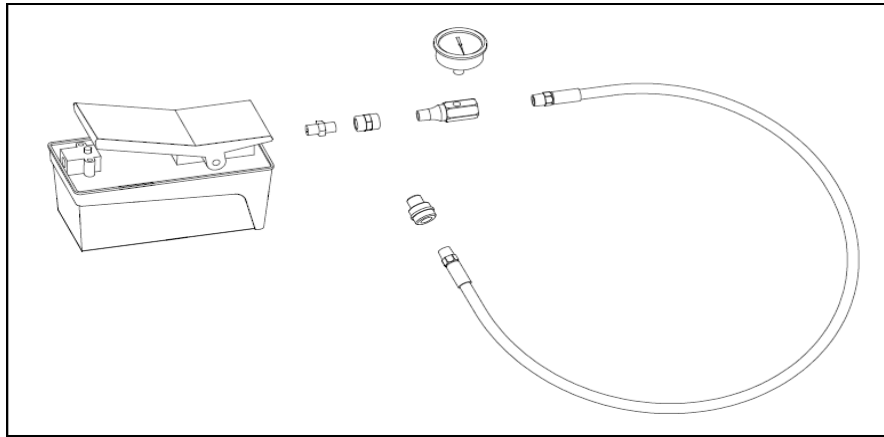

Assemble the hydraulic pneumatic foot pump as shown in the diagram. Apply Teflon tape to all threads making certain it does not obstruct the flow of hydraulic oil.

NOTE: Clean all oil ports of foot pump. Inspect all threads and fittings for wear or damage and replace if needed. Clean all hose ends, couplers and union ends. Remove thread protector from hydraulic fluid outlet port.

Apply Teflon tape to threads of 1/4 inch air coupler and secure air coupler to air input port.

NOTE: The compressed air inlet port is 1/4 inch NPTF. Air must be regulated, lubricated and filtered. A total of 100 psi (7 bar) is recommended. Use a suitable quick connect.

MAINTENANCE

Periodic Maintenance Schedule

The periodic maintenance given in the following paragraphs is the suggested minimum requirements and minimum intervals; accumulated hours or monthly period, which ever comes sooner.

⚠ WARNING Failure to heed this warning can result in death or serious injury, or damage to equipment. If you hear a noise not associated with normal system operation, or, if there is any indication of impending system failure - **CEASE OPERATION IMMEDIATELY!** - Inspect, correct and/or replace parts as required.

⚠ CAUTION To avoid personal injury when performing maintenance function, always wear safety glasses and safety shoes.

NOTE: Refer to Parts Manual for detailed exploded views of referenced parts. Contact Chief Automotive with any questions regarding the usage or maintenance of the Kahuna system.

Periodic maintenance is to be performed on a daily, weekly, and yearly basis as given in the following paragraphs.

Daily Pre-Operation Check (8-Hours)

This daily pre-operational check is shown in the Operation section of this manual as it is performed on a daily basis before use of the lift.

Monthly Maintenance (every month)

On a monthly basis, perform the following checks:

1. Inspect all hydraulic components for leaks, deformation, wear or corrosion.
2. Tighten all fasteners, screws and hydraulic fittings as required.
3. Check all wire connections. Make sure wires are connected properly.
4. Inspect power and control cords for worn insulation or other damage. Replace parts as needed.
5. Check hydraulic fluid. If it is dirty, replace with clean fluid. Always use a clean funnel and filter. Use SUS 215 viscosity @ 100°F (38°C) 10W hydraulic oil.
6. Inspect for cracks in the lock mechanism, and on other parts of the lift. Replace parts as needed.
7. Check for rust on parts. Remove rust, lubricate and paint as needed.

Special Maintenance Tasks

The following items should be performed by a trained maintenance expert.

1. Replacement of hydraulic hoses.
2. Replacement or rebuilding air and hydraulic cylinders as required.
3. Replacement or rebuilding pumps / motors as required.
4. Checking of hydraulic cylinder rod and rod end (threads) for deformation or damage.

NOTE: Relocating or changing components may cause problems. Each component in the system must be compatible; an undersized or restricted line will cause a drop in pressure. All valve, pump, and hose connections should be sealed and/or capped until just prior to use. Air hoses can be used to clean fittings and other components. However, the air supply must be filtered and dry to prevent contamination. Most important - cleanliness - contamination is the most frequent cause of malfunction or failure of hydraulic equipment.

Chain Maintenance

NOTE: The chains/hooks supplied with Chief equipment are high quality, high strength chains/hooks. If replacement is required, purchase only original Chief product from an authorized Chief Automotive representative.

Before each use, chains must be inspected for wear, nicks, gouges, stretched and bent links. If found, replace chain.

Before each use, chain hooks must be inspected for twisted and stretched openings. If found, replace chain.

Refilling Hydraulic Fluid Reservoirs

 **CAUTION** Fill pump reservoirs only after all cylinders have been completely retracted. DO NOT overfill pump reservoirs.

The hydraulic electric pump for the Kahuna lift system contains 2.9 gallons (11 liters) of hydraulic oil. When refilling or adding oil, fill to within 1" (25 mm) of fill port using SUS 215 viscosity @ 100°F (38°C) 10W hydraulic oil.

The hydraulic pneumatic foot pump contains 1.7 liters of hydraulic oil. When refilling or adding oil, fill to within 1" (25 mm) of fill port using SUS 215 viscosity @ 100°F (38°C) 10W hydraulic oil.

Priming the Foot Pump

Occasionally, it may be necessary to prime the foot pump unit. To do this:

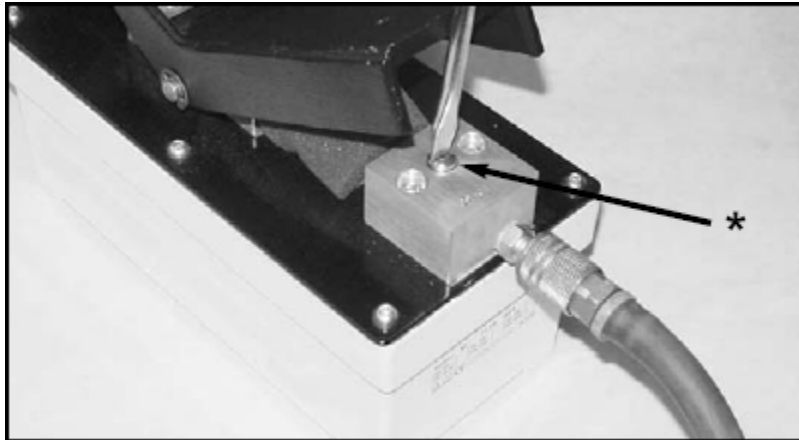

1. Press the release pedal while simultaneously holding down the air intake valve with a flathead screwdriver. The air intake valve is located under the flat portion of the pedal as shown in the above photo.
2. Allow the foot pump to cycle approximately 15 seconds.
3. Remove the screwdriver and press the flat portion of the pedal.
4. If the ram extends or pressure builds, the foot pump has been successfully primed. If not, repeat the procedure.

TROUBLESHOOTING

PROBLEM	CAUSE	POSSIBLE SOLUTION
Pump will not Run	Power cord disconnected	Plug in power cord
	Power cord damaged	Inspect power cord for damage. Contact Chief Automotive service representative for repair or replacement if necessary
	Circuit breaker tripped or blown fuse	Reset circuit breaker or replace fuse on circuit board inside cabinet
	Pendant not connected	Connect pendant to pump cabinet
	Damaged pendant cord	Inspect pendant cord for damage. Contact Chief Automotive service representative for repair or replacement if necessary.
	Faulty wiring connections	Contact Chief Automotive service representative.
	Bad Pendant	Inspect pendant. Contact Chief Automotive service representative for repair or replacement if necessary.
	Bad motor start relay	Replace motor start relay. Contact Chief Automotive service representative for replacement.
	Faulty power unit switch	Contact Chief Automotive service representative for replacement.
	Inadequate power	Rewire facility to comply with local electrical code. Add dedicated line with 20 amp breaker.
Pump will not build pressure or builds pressure slowly	Hydraulic fluid low	Fill fluid reservoir to within 1" (25 mm) of top with SUS215 viscosity @ 100°F (38C) 10W hydraulic oil with all cylinders down and machine in loading position.
	Contamination in pump unload valve	Remove and inspect pump unload valve. Contact Chief Automotive service representative.
Pump will not hold pressure	Hydraulic oil leak	Check hoses, fittings, and quick couplers for leaks. Tighten or replace if necessary
	Contamination in pump unload valve	Remove and inspect pump unload valve. Contact Chief Automotive service representative.
Lift Mechanism does not move up and down smoothly	Vehicle not centered on lift	Move vehicle location on the lift for more equal weight distribution.
	Air in hydraulic system	Bleed hydraulic system. Contact Chief Automotive service representative.
Lift will not raise	Power switch off	Turn power switch on.
	Too much weight	Adhere to 5,500 lb. total weight limit.
	Pump not building pressure	See pump troubleshooting.
Lift does not lift its rated capacity	Vehicle not centered on lift	Move vehicle location on the lift for more equal weight distribution.
	Pump not building pressure	See pump troubleshooting.
Lift will not lower	Bad pump unload valve	Contact Chief Automotive service representative for replacement.
	Bad unload valve coil	Check for magnetic field at the coil. Contact Chief Automotive service representative for replacement if necessary.
	Pneumatic lock release cylinder not fully extending.	Verify 100 psi air pressure. Check for leaks in the air supply tube and fittings. Contact Chief Automotive service representative.
Vector pulling cylinder will not extend	Auxiliary line valve closed	Open auxiliary line valve one turn
	Auxiliary line not connected to cylinder	Connect auxiliary line to cylinder.
	Foot pump will not build pressure	See foot pump problems below.
Vector pulling cylinder will not retract	Auxiliary line valve closed	Open auxiliary line valve one turn
	Auxiliary line not connected	Connect auxiliary line to cylinder
Foot pump fails to shut off	Valve in pump has failed	Contact Chief Automotive service representative.
Foot pump is not pumping fluid or building pressure	Foot pump needs primed.	See information on priming the pump in the Maintenance section of this manual



P.O. Box 1368
Grand Island, Nebraska 68802-1368
Phone: 308/384-9747
Fax: 308/384-8966

www.chiefautomotive.com

**Chief reserves the right to alter product specifications
and/or package components without notice.**