

UMS Pinchweld Stands

USERS MANUAL



The Universal Measuring System (UMS) pinchweld stands are easily installed and adjusted. The equipment in the system not only secures a wide variety of vehicles to a mainframe but also positions vehicles at correct height for UMS usage.

IMPORTANT: The components of this system are manufactured to close tolerances to maintain proper fit of parts and datum height. Handle all components carefully and when not in use, store them to avoid accidental bending or twisting.

When using this holding equipment, follow these guidelines to ensure correct placement of stands and clamps:

1. Position clamp mounts on top of mainframe directly below the ends of the vehicle's rocker panels. The mounts must be installed as shown in Figure 1.
2. Each clamp mount's non-adjustable mounting bracket

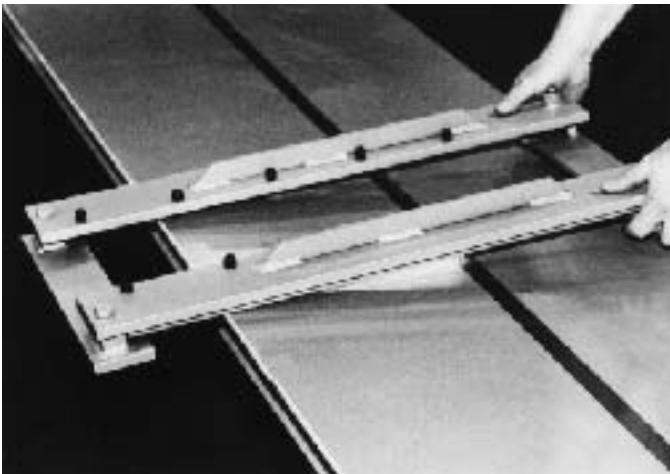

Figure 1

must engage inner edge of mainframe and the adjustable clamp half (outer) must engage outer edge of mainframe. (See Figure 2.) Slide adjustable clamp half in as far as possible making sure it engages outer edge of mainframe. Then secure the bracket's bolts...snug only at this time!

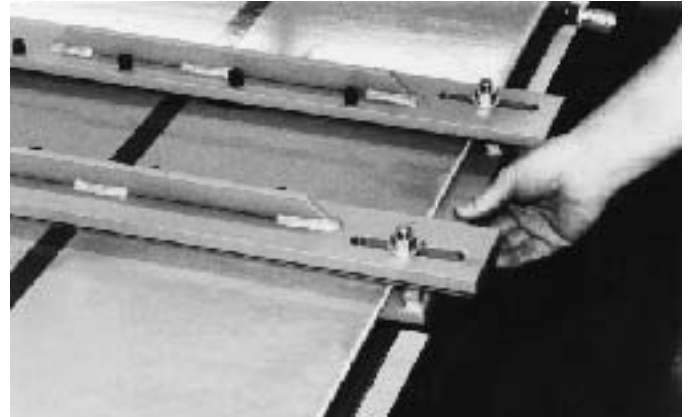

Figure 2

3. Slide anchoring stand (with clamps) into clamp mount and position at desired location. (See Figure 3.)
4. Inspect inside of pinchwelds for fuel lines, brake lines, or other items which may interfere with placement of

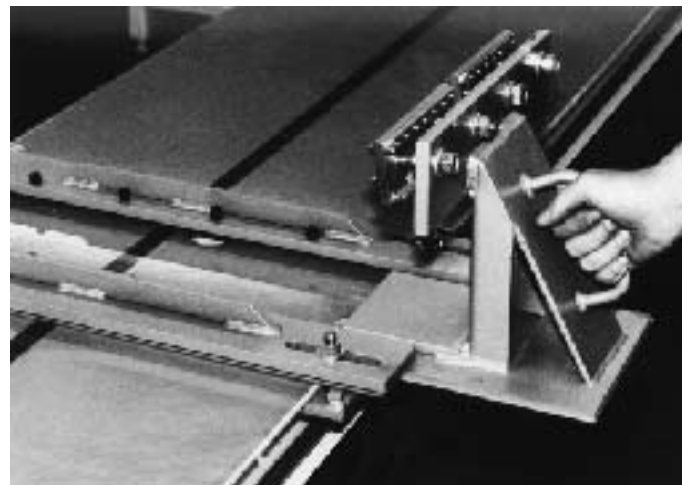

Figure 3

clamps. Remove undercoating from pinchweld.

5. Work on one side of vehicle at a time starting with least damaged side first. Raise vehicle high enough to remove wheels and position clamps under the pinchweld.
6. Lower vehicle until rocker panel pinchweld fits into the clamps.

IMPORTANT: Bottom surface of rocker panel must be firmly against top surface of clamps.

7. Tighten clamp jaw bolts. (Torque to 100 foot pounds maximum.)
8. Tighten adjustable clamp half bolts. (Torque to 100 foot pounds maximum.)
9. Tighten clamp mount hex socket set screws. Tighten snug only!
10. Repeat steps 1-9 on opposite side of vehicle.

Ref.	Part No.	Description
1	498101	Clamp (anchoring stand)
2	498102	Pinchweld standard jaw
3	019095	Washer, 1/2
4	620736	Hex nut, 1/2, Gr. 8
5	010630	Bolt, 1/2 x 2-1/2, HHCS, Gr. 8
6	092110	Spring, SS #LC-055L-3
7	328104	Clamp half (outer)
8	npn	Clamp mount
9	011640	Socket set screws, 1/2 x 1
10	018073	Hex nut, 1/2, Gr. 8
11	010632	Bolt, 1/2 x 3, HHCS, Gr. 8
12	090754	Decal, tighten to 100 ft./lb. max.

Parts Information

To order replacement parts for UMS Pinchweld Stands, contact Chief Automotive Technologies, Inc., 1-800-445-9262. If located outside the United States, contact nearest Chief Automotive Technologies, Inc. representative.

When contacting Chief Automotive Technologies, Inc. by telephone or mail, provide the following information: name, name of shop, shop telephone number, shop address, description of part(s), part number(s), method of payment and shipping charges.

NOTE: Chief Automotive Technologies, Inc. reserves the right to alter product specifications and/or package components without notice.

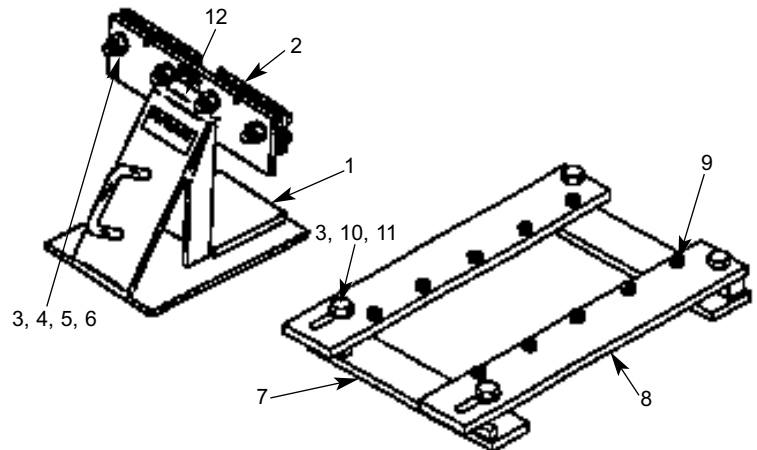

CHIEF'S LIMITED ONE-YEAR WARRANTY & LIABILITY

Chief Automotive Technologies, Inc. warrants for one year from date of installation and/or purchase any of its products which do not perform satisfactorily due to defect caused by faulty material or workmanship. Chief's obligation under this warranty is limited to the repair or replacement of products which are defective and which have not been misused, carelessly handled, or defaced by repair or repairs made or attempted by others.

CHIEF AUTOMOTIVE TECHNOLOGIES, INC. DOES NOT ASSUME RESPONSIBILITY FOR ANY DEATH, INJURY OR PROPERTY DAMAGE RESULTING FROM THE OPERATOR'S NEGLIGENCE OR MISUSE OF THIS PRODUCT OR ITS ATTACHMENTS. CHIEF MAKES NO WRITTEN, EXPRESS OR IMPLIED WARRANTY WHATSOEVER OF MERCHANTABILITY OR FITNESS FOR A PARTICULAR PURPOSE OR OTHERWISE REGARDING THE EQUIPMENT OR ANY PART OF THE PRODUCT OTHER THAN THE LIMITED ONE-YEAR WARRANTY STATED ABOVE.

Returned merchandise requires a "RETURNED GOODS AUTHORIZATION NUMBER" on the package. Authorization numbers can be obtained by calling or writing the Customer Service Department, Chief Automotive Technologies, Inc. No returned merchandise will be accepted without an authorization number. All returned merchandise must be shipped freight prepaid (and may be subject to a handling and restocking charge) to:

Chief Automotive Technologies, Inc.
Attn: Returned Goods Dept.
1924 E. Fourth St.
P.O. Box 1368
Grand Island, Ne. 68802
308-384-9747

or

Your Authorized
Chief Automotive Technologies, Inc.
Representative



P.O. Box 1368

Grand Island, Nebraska 68802-1368

Phone: 308/384-9747

Fax: 308/384-8966

www.chiefautomotive.com

**Chief reserves the right to alter product specifications
and/or package components without notice.**