

Megane Attachments

USERS MANUAL





CHIEF'S LIMITED ONE-YEAR WARRANTY & LIABILITY

Chief Automotive Technologies, Inc. warrants for one year from date of installation and/or purchase any of its products which do not perform satisfactorily due to defect caused by faulty material or workmanship. Chief's obligation under this warranty is limited to the repair or replacement of products which are defective and which have not been misused, carelessly handled, or defaced by repair or repairs made or attempted by others.

CHIEF AUTOMOTIVE TECHNOLOGIES, INC. DOES NOT ASSUME RESPONSIBILITY FOR ANY DEATH, INJURY OR PROPERTY DAMAGE RESULTING FROM THE OPERATOR'S NEGLIGENCE OR MISUSE OF THIS PRODUCT OR ITS ATTACHMENTS. CHIEF MAKES NO WRITTEN, EXPRESS OR IMPLIED WARRANTY WHATSOEVER OF MERCHANTABILITY OR FITNESS FOR A PARTICULAR PURPOSE OR OTHERWISE REGARDING THE EQUIPMENT OR ANY PART OF THE PRODUCT OTHER THAN THE LIMITED ONE-YEAR WARRANTY STATED ABOVE.

Installation Procedures

Before installing anchoring attachments insert:

- Adapter Tubes in Universal Anchoring Stand Bases and insert height adjusting pins. (See Figure 1.)
- Clamp Bar Tubes in Universal Anchoring Stand Bases and insert height adjusting pins. (See Figure 2.)

Then position anchoring stands at four corners of vehicle's center section.

Front Adapters

1. At right front corner of center section insert oval T-bolt in square-shaped reference hole on underside of rocker panel. (See Figure 3.) Turn bolt head so that it straddles the reference hole allowing bolt to hang freely from the reference hole.

2. Position right front adapter plate against subrail on underside of rocker panel. Oval T-bolt must extend downward through slot in rail. (See Figure 4.) Secure adapter plate to subrail using 12mm nut and 1/2 ASTM washer.

NOTE: Shape of adapter plate matches shape of subrail on underside of rocker panel.

3. Slide inside rail base into vehicle's subrail as shown at far right of Figure 5. Then secure the inside rail base to the front adapter plate using 12mm bolt and 1/2 ASTM washer. Bolt extends upward through slot in adapter plate and hole in subrail and threads directly into hole in support bar.

4. Repeat steps 1 — 3 to install front adapter plate at left front corner of center section.

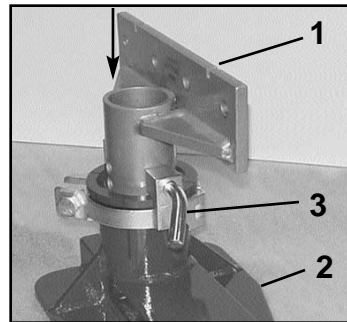

Figure 1

- 1 - Adapter Tube
- 2 - Universal Anchoring Stand Base
- 3 - Height Adjusting Pin

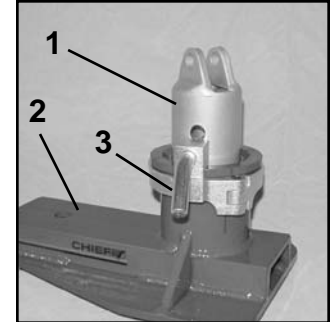

Figure 2

- 1 - Clamp Bar Tube
- 2 - Universal Anchoring Stand Base
- 3 - Height Adjusting Pin

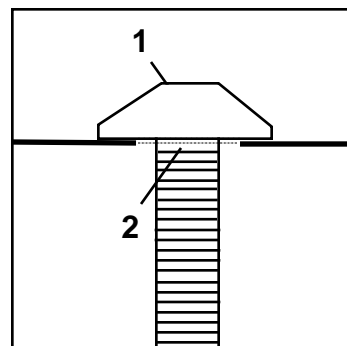

Figure 3

- 1 - Oval T-Bolt
- 2 - Square-Shaped Reference Hole

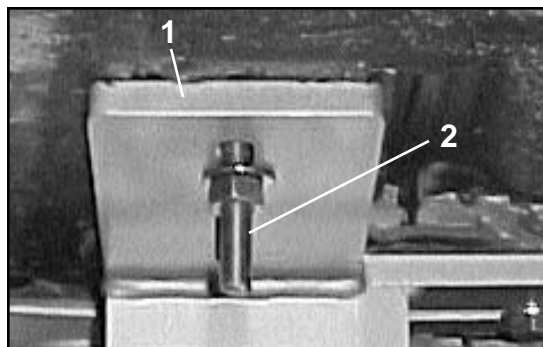

Figure 4

- 1 - Front Adapter Plate
- 2 - Oval T-Bolt

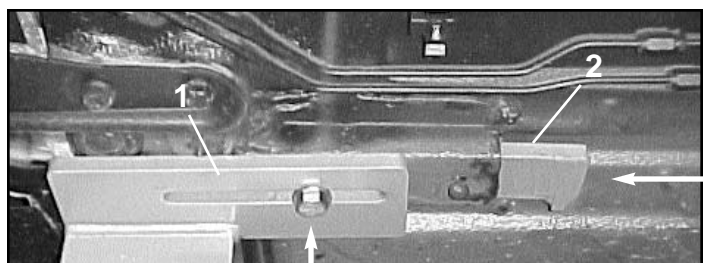

Figure 5

- 1 - Front Adapter Plate
- 2 - Inside Rail Base

Rear Adapters

1. At right rear corner of center section, install anchoring components as shown in Figure 5. When installing components follow these steps:

- a. Install a pair of oval T-bolts in square-shaped reference holes on underside of rocker panel. Turn each bolt head so that it straddles the reference hole allowing bolt to hang freely from the reference hole.
- b. Attach pinchweld clamp to L Bracket using 14mm bolts and nuts and 1/2 Series W washers. (See Figure 6.) Then secure the assembly to vehicle's pinchweld (flange) next to the suspended oval T-bolts. (See Figure 6.)
- c. Position right rear adapter plate against subrail on underside of rocker panel. Oval T-bolts must extend through slot in adapter plate. (See Figure 6.) Secure adapter to subrail using 12mm nuts and 1/2 ASTM washers. Then secure L bracket to adapter plate using 12mm bolts and nuts and 1/2 ASTM washers. (See Figure 6 and Figure 7.)

IMPORTANT: Slots in L bracket allow pinchweld clamp to align with pinchweld (flange).

NOTE: Half clamps are provided for those applications where pinchweld (flange) space is limited.

2. Repeat Step 1 (a - c) at left rear corner of center section.

Attach To Anchoring Stand Adapter Tubes

Attach front anchoring assemblies to front vertical surface of anchoring stand adapter tubes. (See Figure 8.) Then attach rear anchoring assemblies to back vertical surface of anchoring stand adapter tubes. (See Figure 9.)

IMPORTANT: Attach the assemblies to the two middle holes of the adapter tubes using 12mm bolts and nuts and 1/2 ASTM washers.

Attach To Anchoring Stand Clamp Bar Tubes

Position front and rear anchoring assemblies between Clamp Bar Tube ears. (See Figure 10.) Insert two M16 washers to fill gap between the ears and secure the assembly using an M16 nut and bolt.

Adjust And Secure Anchoring Stands

After attaching all four anchoring assemblies to anchoring stands, adjust each stand to the correct height and tighten all nuts and bolts. Then secure the anchoring stands to the mainframe using tie down plates and bolts.

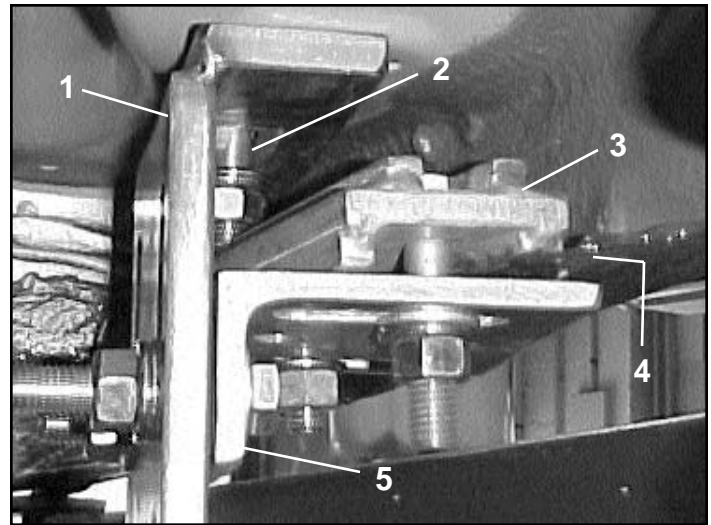

Figure 6

- | | |
|------------------------|------------------------|
| 1 - Rear Adapter Plate | 4 - Pinchweld (Flange) |
| 2 - Oval T-Bolt | 5 - L Bracket |
| 3 - Pinchweld Clamp | |

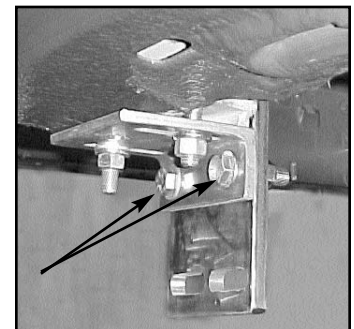

Figure 7



Figure 8

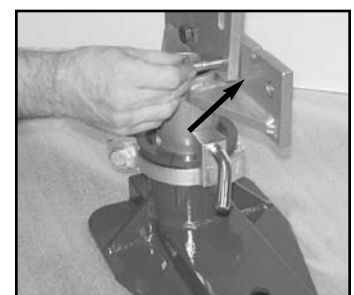

Figure 9

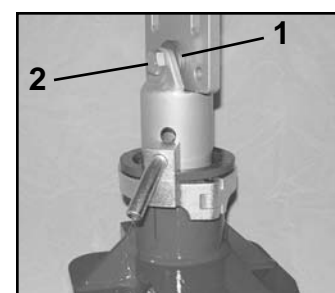

Figure 10

- 1 - Two Flat Washers, M16
- 2 - Bolt, M16 x 2 x 55mm
(Nut, M16 x 2, Hex - hidden from view)

Parts Information

To order replacement parts for the Megane Attachments, contact Chief Automotive Technologies, Inc. 800-445-9262. (If outside the United States, contact your nearest Chief Automotive Technologies, Inc. representative.)

When contacting Chief Automotive Technologies, Inc. by telephone or mail, provide the following information:

name, name of your business, business telephone number, and business address. Additional information needed when ordering: description of part(s) and part numbers.

NOTE: Chief reserves the right to alter product specifications and/or package components without notice.

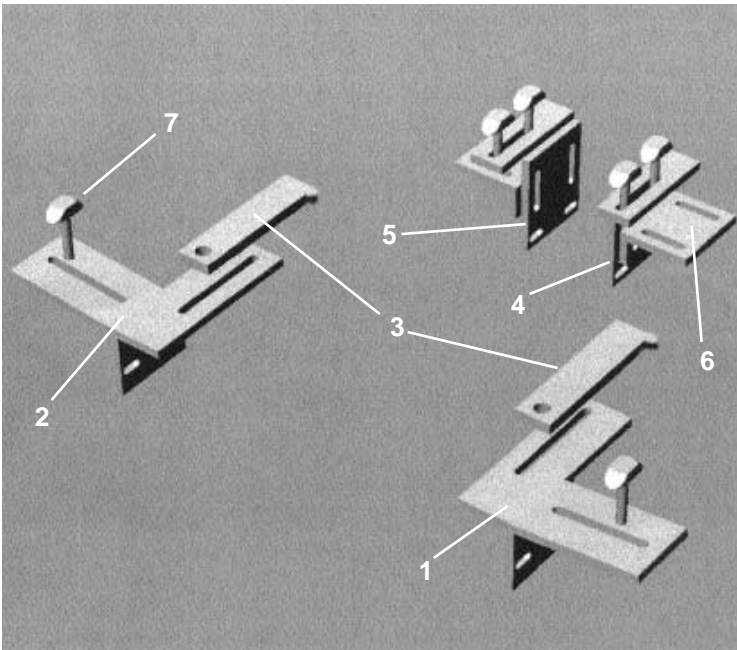

Ref.	Part No.	Description
1	519765	Left Front Adapter Plate
2	519766	Right Front Adapter Plate
3	519756	Inside Rail Base
4	519767	Left Rear Adapter Plate
5	519763	Right Rear Adapter Plate
6	519762	Small L Bracket
7	519761	Oval T-Bolt Assembly
*	401250	Pinchweld Jaw, Metric
*	401234	Bolt, M14 x 2.0 x 60mm HHCS
*	401235	Nut, M14 x 2.0mm, Plated
*	629909	Washer, 1/2, Flat, Series W, PI
*	539021	Bolt, M12 x 1.75 x 45mm HHCS
*	539024	Nut, M12 x 1.75mm, Hex
*	019095	Washer, 1/2 ASTM F436
*	518700	Half Clamp Assembly, Left
*	518701	Half Clamp Assembly, Right
*	539027	Bolt, M16 x 2.0 x 55mm HHCS
*	539018	Nut, M16 x 2.0mm, Hex
*	539019	Washer, Flat, M16

* **Not Shown**



**P.O. Box 1368
Grand Island, Nebraska 68802-1368
Phone 308-384-9747
Fax 308-384-8966**

www.chiefautomotive.com

**Chief reserves the right to alter product specifications
and/or package components without notice.**