

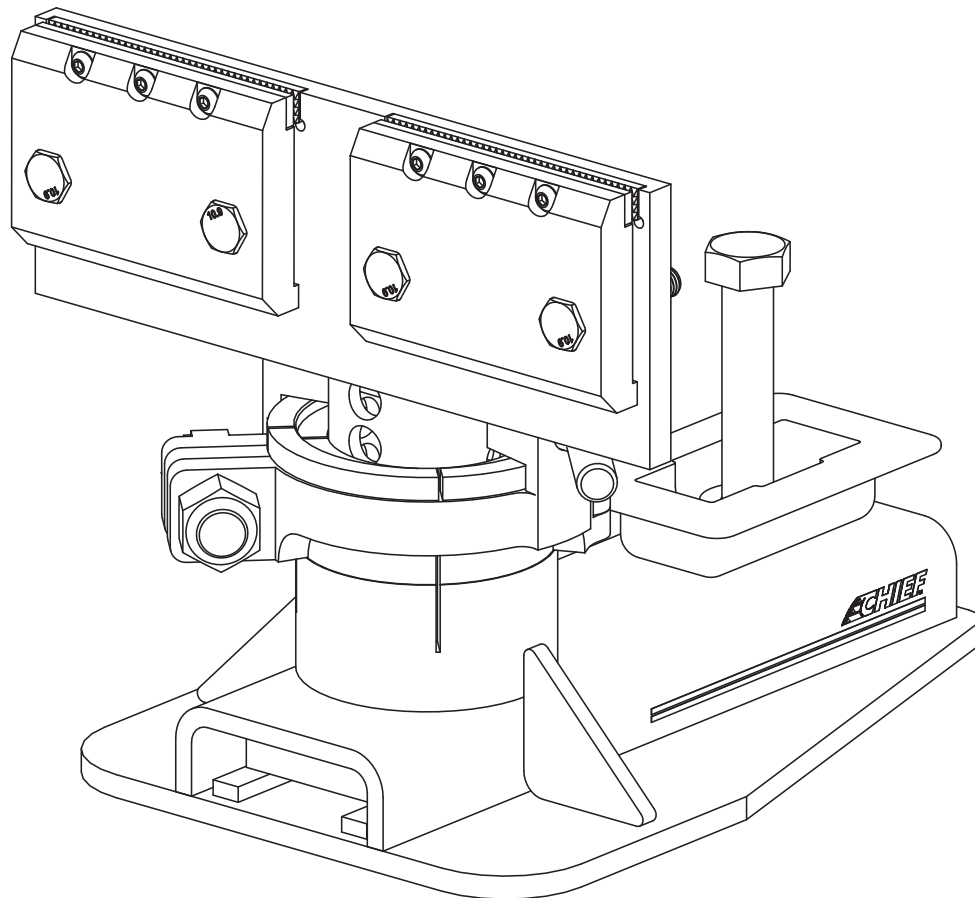

# Universal Anchoring

## Serrated Double Bolt Jaw

### Users Manual



## CHIEF'S LIMITED ONE-YEAR WARRANTY & LIABILITY

Chief Automotive Technologies warrants for one year from the date of installation and/or purchase any of its products which do not perform satisfactorily due to defect caused by faulty material or workmanship. Chief's obligation under this warranty is limited to the repair or replacement of products which are defective and which have not been misused, carelessly handled, or defaced by repairs made or attempted by others.

CHIEF AUTOMOTIVE TECHNOLOGIES DOES NOT ASSUME RESPONSIBILITY FOR ANY DEATH, INJURY OR PROPERTY DAMAGE RESULTING FROM THE OPERATOR'S NEGLIGENCE OR MISUSE OF THIS PRODUCT OR ITS ATTACHMENTS. CHIEF MAKES NO WRITTEN, EXPRESS OR IMPLIED WARRANTY WHATSOEVER OF MERCHANTABILITY OR FITNESS FOR A PARTICULAR PURPOSE OR OTHERWISE REGARDING THE EQUIPMENT OR ANY PART OF THE PRODUCT OTHER THAN THE LIMITED ONE-YEAR WARRANTY STATED ABOVE.

## Installation

The installation procedures for Universal Anchoring System begin when positioning vehicle on pulling system. Technicians must allow adequate pulling room between machine's towers and vehicle (18 to 24 inches) and allow enough room for vehicle's length once corrected. This positioning, coupled with flexibility of the anchoring system, allows for repairing specific types of damage. For example: center vehicle on mainframe when repairing 'front hits' or 'rear hits'; position vehicle to side of mainframe when repairing 'side hits'.

**CAUTION** Set vehicle's parking brake and block its wheels to prevent vehicle movement during installation of anchoring system.

1. Attach two clamp jaws to the vertical plate of the adapter tube, install tube in anchoring stand base (see Figure 1) and position stand at front of center section on side of vehicle that must not move with pull.
2. Prepare a second anchoring stand (as required) and position it on same side of vehicle at rear of center section.
3. Position lifting device under subrail (or other structurally sound component). Lift entire side of vehicle high enough to install anchoring stands at both front and rear of center section.

4. Position anchoring stands directly below anchoring locations on pinchweld. Prior to positioning, observe pinch-welds to determine where clamp jaws should be attached. If possible, select reinforced pinchwelds that are free of obstructions (lines, etc.). Select locations in corners of center section and avoid locations in center of rocker. If pinchweld configuration requires use of optional accessory, see page 2.

Center locating plate in most convenient rectangular tie down hole below attachment point on pinchweld. Anchoring stand installs more easily with locating plate positioned in tie down hole 3 to 4 inches outboard of attachment points.

5. Adjust front and rear anchoring stand height so clamp jaws engage (or are just below) rocker panel pinch weld and insert height adjustment pins in pinning holes.

6. Lower entire side of vehicle to engage pinchweld in the clamp jaws. Then tighten clamp jaw bolts.

**IMPORTANT** Rocker must rest firmly on top of clamp jaw assembly prior to tightening.

7. Install anchoring stands on opposite side of vehicle. Repeat Steps 1 - 6.

8. Secure anchoring stands to mainframe using tie down plates and bolts.

9. Tighten clamp jaws and locking collars.

**IMPORTANT** Clamp jaws must be retightened after initial pulls are made. Clamp jaws will seat themselves during initial pull, resulting in a loosening of the clamp jaws. Clamp jaws may slip if not retightened.

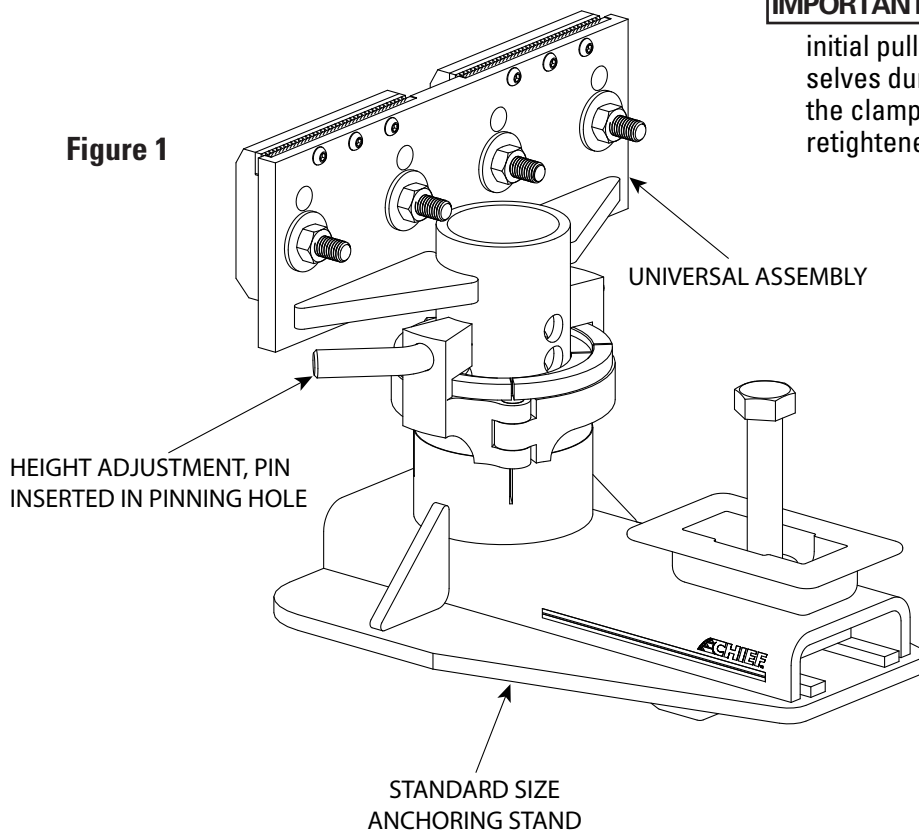

## **Flexibility Of Anchoring Systems**

UAS components are capable of height adjustment, vertical movement and lateral movement.

### **Height Adjustment**

Adapter tubes adjust to varying heights dependent upon repair and/or measuring needs. This adjustment allows for vehicle placement at identified locations or at a different level that's more conducive to pulls required.

### **Vertical Movement**

When correcting twist, anchoring stands at low and high corner of center section are secured to vehicle and mainframe, however, anchoring tubes are not pinned to the anchoring stands. This setup allows vertical movement when pulls are applied to correct the twist. Once corrected, adapter tubes are pinned to the stands and remaining repair work addressed.

### **Lateral Movement**

When correcting either diamond or a direct side hit, one or both anchoring stands on the damaged side of the vehicle can be attached to the vehicle but not secured to the mainframe. This setup allows for lateral movement when pulls are applied to remove center section damage. Once the damage is corrected, anchoring stands are secured to the mainframe and remaining repair work addressed.

## **Optional Accessories**

A variety of optional accessories are available for vehicles that are difficult to anchor. Such vehicles have unique pinchweld or frame rail configurations that may require specially designed pinchweld clamp bars, brackets, pins, adapters, adapter tubes or crossmembers.

Some of the optional accessories are in a tube design (for insertion in anchoring stands), whereas other accessories mount directly to the Universal adapter tubes identified in this manual.

For information on all anchoring accessories, contact Chief Automotive Technologies, Inc., 800-445-9262. (If located outside the United States, contact the nearest Chief Automotive Technologies, Inc. representative.)

**Parts Information**

To order replacement parts for Universal Anchoring Systems, contact Chief Automotive Technologies, Inc. 800-445-9262. (If outside the United States, contact nearest Chief Automotive Technologies, Inc. representative.) When contacting Chief Automotive Technologies, Inc. by telephone or mail, provide the following information: name, name of shop, shop telephone number, shop address, description of part(s) and part number(s).

**NOTE:** Illustration and list reflect replacement parts for Universal Anchoring Systems. Some parts may not pertain to system purchased.

**702082  
UNIVERSAL ANCHORING SYSTEM  
METRIC SHORT**

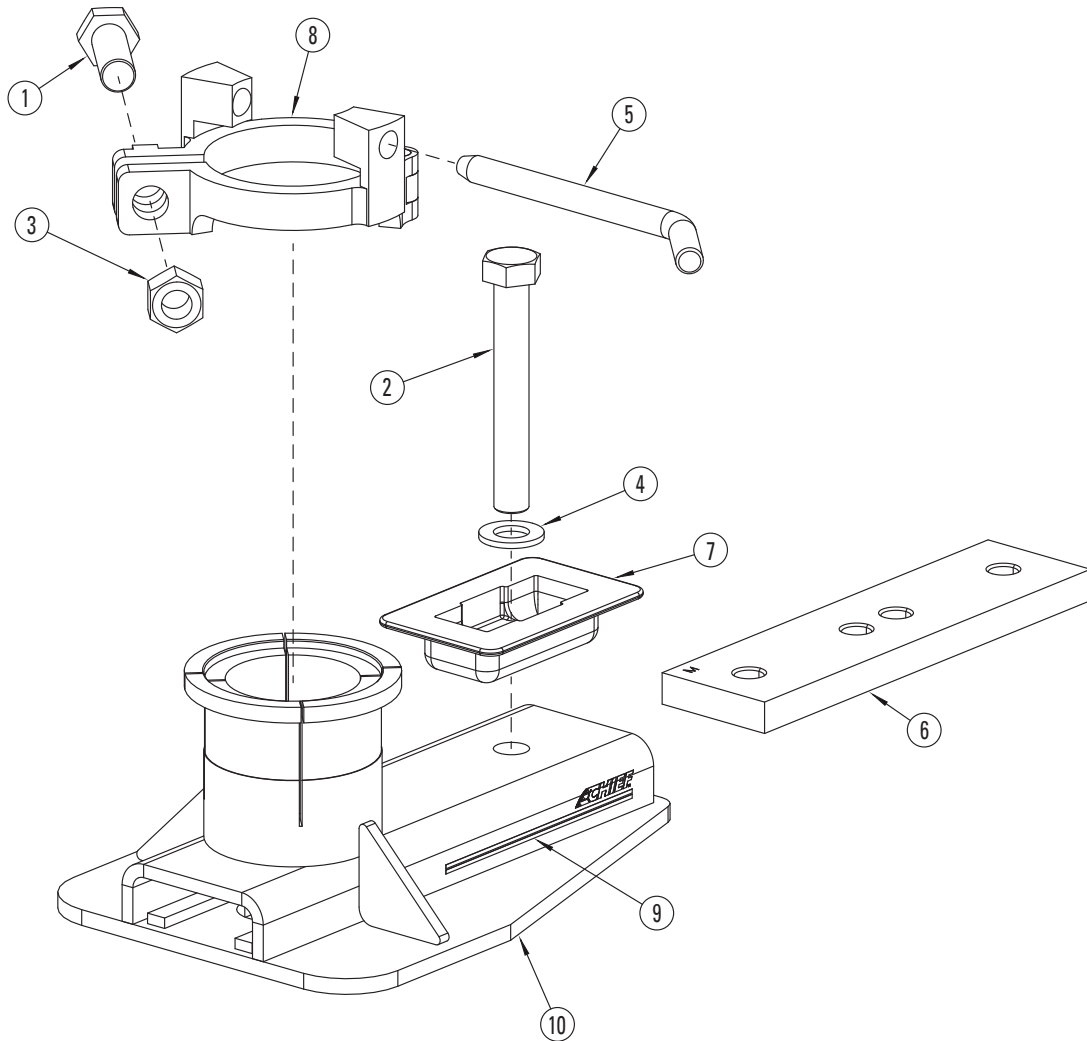

ITEM	QTY	PART NO.	DESCRIPTION
1	1	539006	BOLT, HEX, M20 X 2.5 X 60MM, PLATED, HHCS
2	1	539008	BOLT, HEX, M20 X 2.5 X 140MM
3	1	539016	M20 X 2.5 HEX NUT, PLAIN
4	1	601738	3/4" FLAT WASHER, PLTD
5	1	606686	HEIGHT ADJUSTING PIN, UAS, PLATED
6	1	606860	FASTENER BAR, UAS METRIC
7	1	607371	FASTENER PLATE, UAS
8	1	607381	LOCKING COLLAR ASS'Y
9	2	621472	DECAL, CHIEF W/STRIPES
10	1	702067	UNI-BODY STAND ASSEMBLY

## CK110017 UAS ASSEMBLY SERRATED

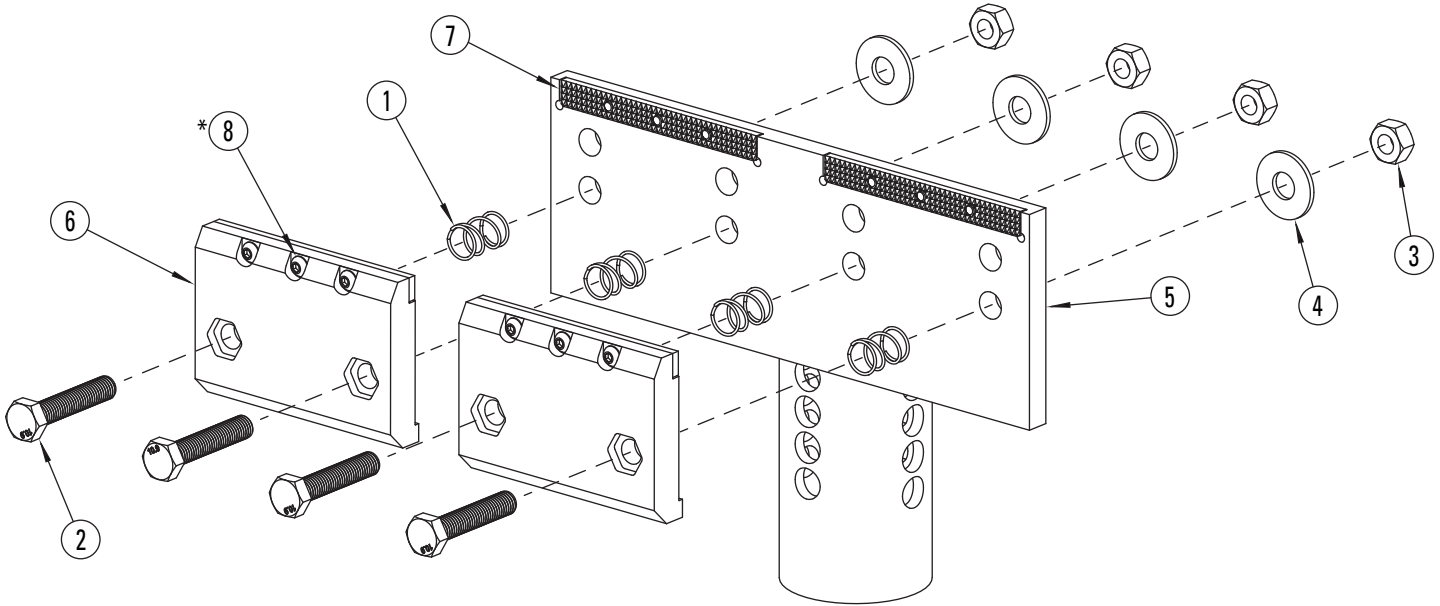

ITEM	QTY	PART NO.	DESCRIPTION
1	4	092110	SPRING, COMPRESSION .720" X 1"
2	4	539002	M12 X 1.75MM X 60MM HHCS Grd. 10.9
3	4	638103	M12 X 1.75 HEX NUT, PLAIN
4	4	912605	1/2" FLAT WASHER
5	1	CK110018	ADAPTER TUBE ASSEMBLY UAS SERRATED
6	2	CK110020	SERRATED JAW ASSEMBLY
7	4	CK110009	SERRATED JAW INSERT
8	12	*CK110008	BUTTON-HEAD SOCKET C.S. M6 X 1.0 X 14MM LONG

**\*NOTE:**  
1. APPLY THREAD LOCKER #242 OR EQUAL  
TO EACH SCREW AND TIGHTEN.

# MAINTENANCE INSTRUCTIONS

## **WARNING**

If you are not completely familiar with Chief Pulling Equipment maintenance procedures **STOP**. Contact factory for instruction details. Permit only qualified personnel to perform maintenance on this equipment.

- **Always:** Keep all bolts tight. If lost, replace as required and as described in this manual.
- **Always:** Keep Anchor Stand area clean and free of tools, debris, grease, etc.
- **Always:** Keep Serrated Jaw Insert hardware (Button-Head Socket C.S. M6x1.0x 14mm) tight. Apply thread locker #242 or equal to each screw when replacing.
- **Always:** Keep Serrated Jaw Inserts clean and free of debris, etc.
- **Monthly:** Check Anchor Stand Assembly for distortion, broken parts, etc. Replace as needed.
- **Monthly:** Check Serrated Jaw Inserts for worn or damaged teeth. Replace as needed.
- **Monthly:** Check Height Adjustment Pin and Locking Collar for worn or distorted parts, etc. Replace as needed.
- **Monthly:** Check all fastener hardware for worn or distortion. Replace as needed.



Chief Automotive Technologies  
996 Industrial Drive  
Madison, IN 47250  
Phone: 800-445-9262  
Fax: 866-275-0173



[www.chiefautomotive.com](http://www.chiefautomotive.com)

Chief reserves the right to alter product specifications  
and/or package components without notice.